

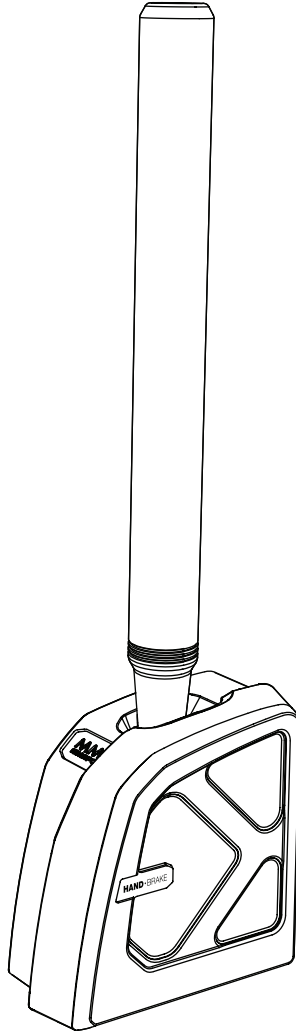

HAND • BRAKE



QUICK GUIDE

1. Package content

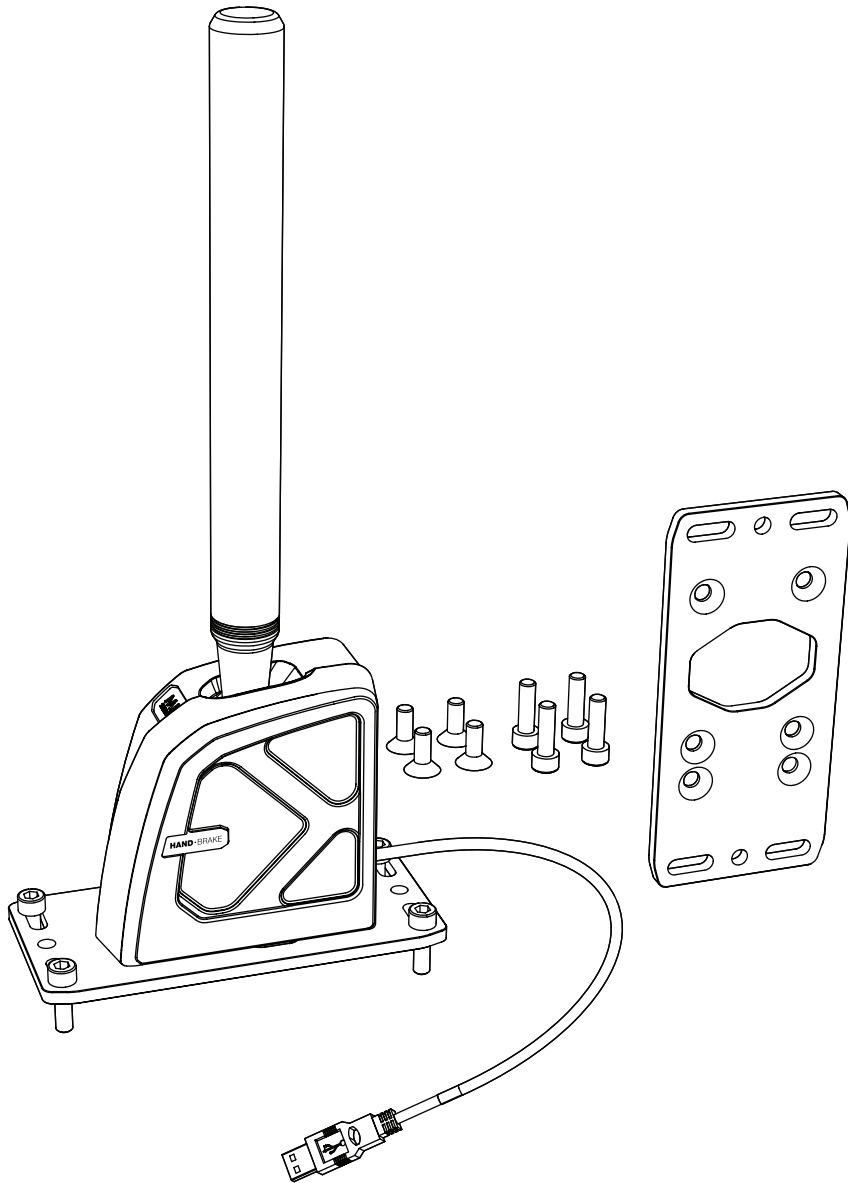

2. Mounting

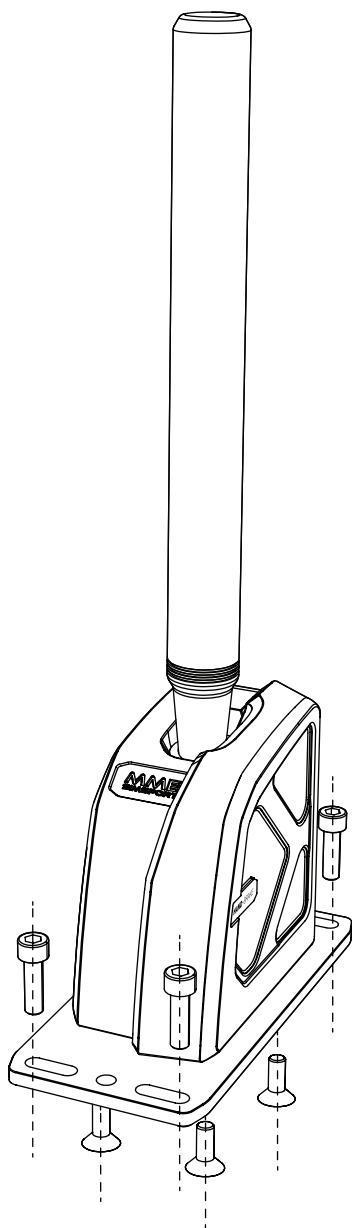

3. Calibrating pressure

Handbrake shipped has already been calibrated. Re-calibration is needed only, if different pressure is desired.

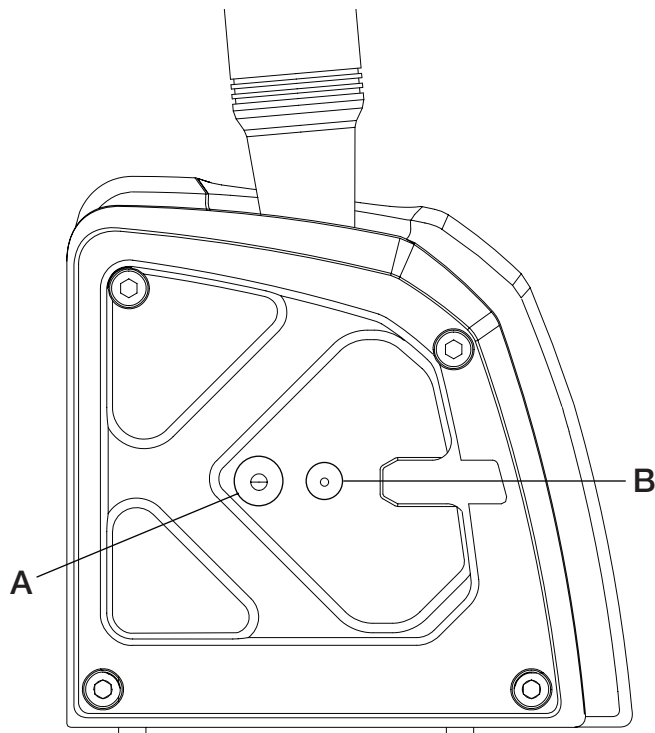

Calibration steps:

1. Use small bit to access the calibration button **(B)** and hold that button for 3 seconds.
2. LED **(A)** will start to blink.
3. Move the lever to desired position. This will be your new maximum pressure.
4. After 5 seconds LED will blink fast 5 times. Calibration is finished.

4. Connecting with shifters

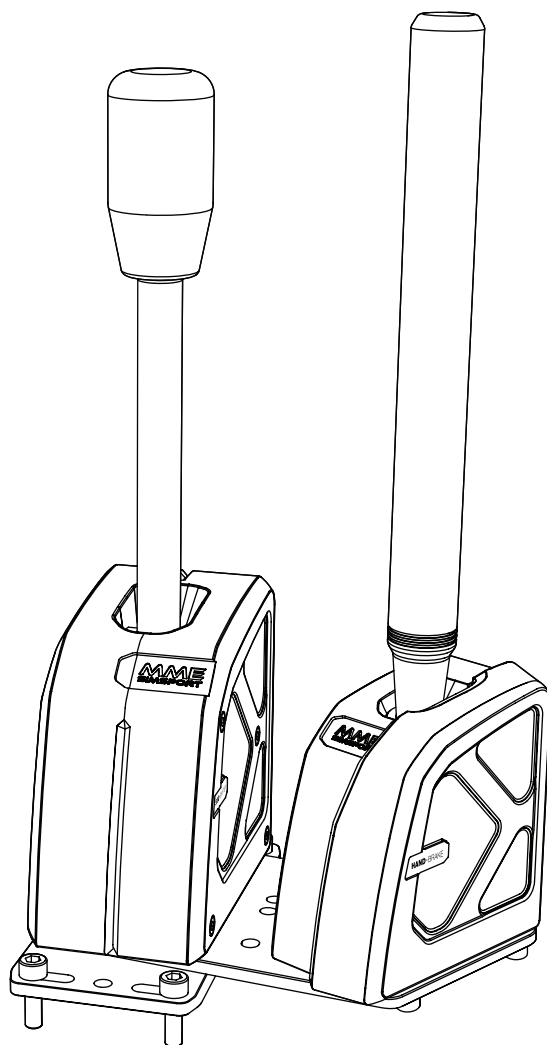

HB + SEQ

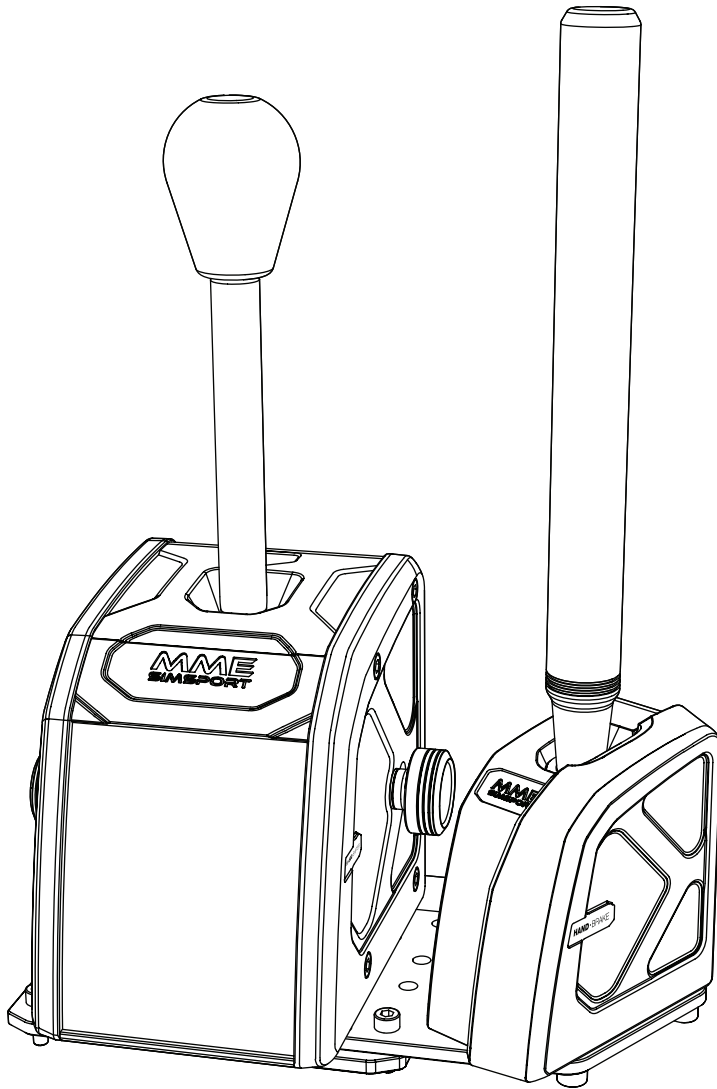

HB + H+SEQ





Sim
Racing
Technology

MME Motorsport Ltd.

Dobračevska 55
4226 Žiri
Slovenia

www.mme-motorsport.com/en/