

EN

KING OF THE ENTRY
LEVEL IMMERSION



USER MANUAL

QS BT1

Contents

1	Introduction	3
2	Safety precautions	3
3	Essential Information	4
4	Technical details	6
4.1	Intended use	6
4.2	List of components	6
4.3	Operating and storage conditions	7
4.4	Dimensions and weight	7
4.5	Power supply specification	10
4.6	Power requirements and consumption	10
4.7	Noise emission	11
5	Setup and installation	12
5.1	Attaching to the aluminum based cockpit profile	12
5.2	Attaching to QS-CH1	16
5.3	Attaching to QS-V20	19
5.4	Attaching to QS-S25	23
5.5	Attaching to Next Level Racing Motion Platform V3	26
5.6	Belt installation	29
5.6.1	Attaching harness to the platform	29
5.6.2	Attaching tensioner buckles to the harness	32
5.6.3	Seat inserts	37
5.7	Seat belt settings	38
5.7.1	Seat belt setup	38
5.7.2	Vehicle vs. flight simulations setup	39
5.8	Cable connections	40
5.8.1	Basic connection diagrams	40
5.8.2	Motion Lock connection diagrams	41
5.8.3	Implementing non-factory Motion lock switch	44
5.9	Post-assembly check list	45
6	Software	46
6.1	QS-BT1 software compatibility	46
6.2	Download and installation	47
6.3	Adjustments	49
7	Operation	51
8	Troubleshooting	52
8.1	Common problems with solutions	54
8.2	Creating a snapshot	60
8.3	Discord channel	62
9	Environmental Impact and Disposal	63

10 Liability Disclaimer	63
11 Warranty	64
12 Copyright	65
13 Manufacturer information	65

Document revision history

Ver.	Date	Comment
1.0	2024-05-31	First release
1.1	2024-06-31	Added sections with mounting adapters for QS-S25, QS-V20, QS-CH1, NLR MP V3, added new components to component list.
1.2	2024-09-02	Added chapter Advanced application, Post-assembly check list, updated belt connection diagrams.
1.3	2025-01-08	Updated device mounting method with all adapter plates, updated illustrations for revised accessories, added section Most common problems with solutions.

1. INTRODUCTION

QS-BT1 is a multi-purpose, dual-channel, direct-drive seat belt tensioner that increases the immersion of a racing simulator. It is powered by the same technology as QS-220 and provides force feedback similar to that offered by direct-drive wheels. QS-BT1 generates vibrations to simulate a running engine, tensions up with downshifts, upshifts, in corners, and finally - gives a strong pull when crashing. Importantly, it can also work as a standalone, fully independent device.

2. SAFETY PRECAUTIONS

WARNING



The device is intended solely for individuals over the age of 16. In case of use by individuals with limited physical, sensory, or mental capabilities, strict supervision is required. Read safety instructions before using the device.

WARNING



The device is not allowed to be used by a pregnant woman.

WARNING



DO NOT use the device around pets.

WARNING



DO NOT place hands, neck, or head under or wrap them around the belts.

WARNING



Always ensure that cockpit attachment points can withstand forces generated by the device (approved construction or tested for expected load). The maximum force generated by the QS-BT1 is 200 N on each belt.

WARNING



Keep in mind that dangerous voltage levels can remain in electrical circuits of the device for up to a few minutes after powering off.

3. ESSENTIAL INFORMATION

INFO

Read all the safety instructions before installing and using this product. Save this document for future reference. If ownership of this product is transferred, be sure to include this manual.

To reduce the risk of burns, fire, electrical shock, injury or mechanical damage:

- Use the QS-BT1 only for its intended purpose, according to instructions.
- Unplug the QS-BT1 from the power supply if it is not used for an extended period of time or when there is a need to perform hardware installation, maintenance, service or repair.
- Turn off the QS-BT1 when it is not in use.
- The QS-BT1 was designed for indoor use only - **DO NOT** store or use the product outdoors.

-
- Keep the QS-BT1 away from heat sources, high humidity, water, and other liquids. **DO NOT** store in places where water vapor condensation may occur due to low temperatures.
 - **DO NOT** disassemble the product. Any tampering with or altering the product will void the warranty, pose a serious risk of electric shock, and may irreparably damage the product.
 - If the device starts emitting unusual noises, smoke, or indicating that the device is not working properly, **STOP** using the QS-BT1 immediately and contact technical support.
 - **DO NOT** cover the ventilation holes in the device.
 - Keep the power cord plug and the socket dry, clean and dust-free.
 - Protect the power cord from being damaged by being stepped on, rubbed against, or pinched.
 - **DO NOT** use the QS-BT1 if the ambient temperature is below 5°C (41°F) or above 40°C (104°F).
 - **DO NOT** use the QS-BT1 if it has been damaged, or any component is broken or missing. Please contact technical support.
 - **DO NOT** use attachments or replacement parts not recommended or approved by the manufacturer. If you must replace a damaged power cord, use only certified products with the same rating as the one being replaced.
 - Before each use of the device ensure that it is securely mounted to the motion rig.
 - Before each use of the device ensure that belt buckles are securely mounted to the harness.
 - Use only certified components (seat belts, fasteners) when installing QS-BT1 to your motion rig.
 - Use 5 or 6-point racing harness, with adjusters (look at point A in the drawing below), preferably with FIA certification.

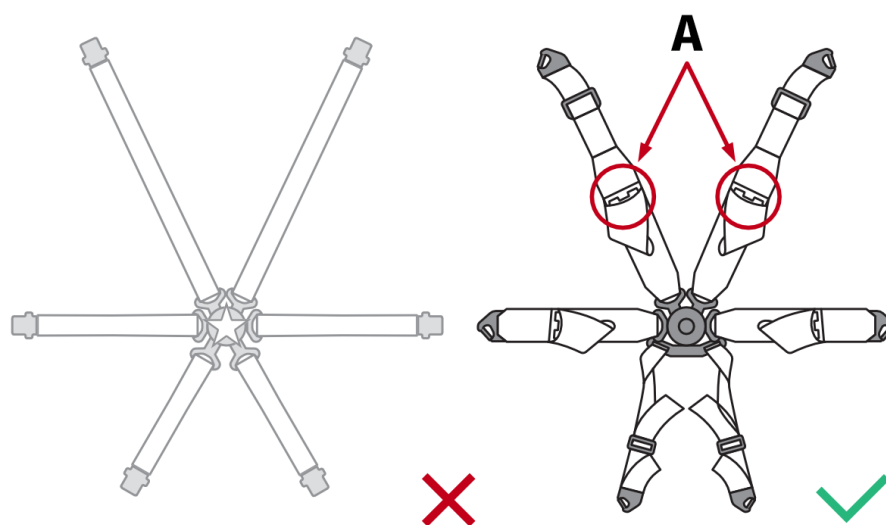

4. TECHNICAL DETAILS

4.1. INTENDED USE

The device is intended to work as a **INDOOR** seat belt tensioner for vehicle and flight simulations. It is not classified as a safety device and can be used **ONLY** for entertainment and training purposes.

WARNING

It is forbidden to use the device in applications other than intended.

4.2. LIST OF COMPONENTS

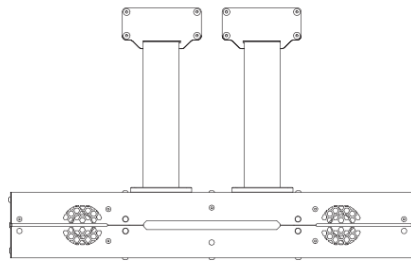

**Main unit
QS-BT1
(x 1)**

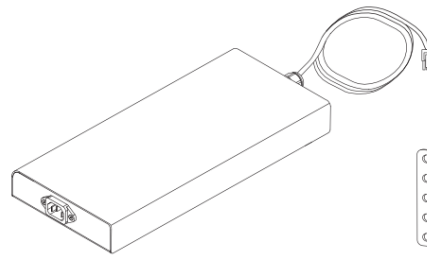

**Power supply
(x 1)**

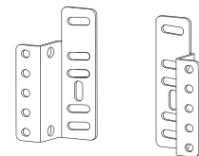

**Universal mounting
adapters and
fasteners
(x 2)**



**Belt buckles
and fasteners
(x 2)**



**Power supply
cable
(x 1)**



**Motion Lock
interlink cable
(x 1)**



**USB cable
(x 1)**



**Low friction inserts
and velcro strips
(x 2)**



**Motion lock jumper
(x 1)**

INFO

The QS-BT1 package does not include racing harness; user needs to obtain it separately.

4.3. OPERATING AND STORAGE CONDITIONS

QS-BT1 should be operated and stored within conditions as specified below:

- Only indoor use and storage
- Temperature: 5°C - 40°C (41°F - 104°F)
- Humidity: 0% - 70% (without water vapor condensation)
- Maximum altitude: 0 - 2000 m (6561 ft)
- Ensure a correct distance from QS-BT1's cooling vents on the backside (min. 15 cm / 6 in.) and on the frontside (min. 3 cm / 1.18 in.), and for cable plugs underneath (min. 15 cm / 6 in.).

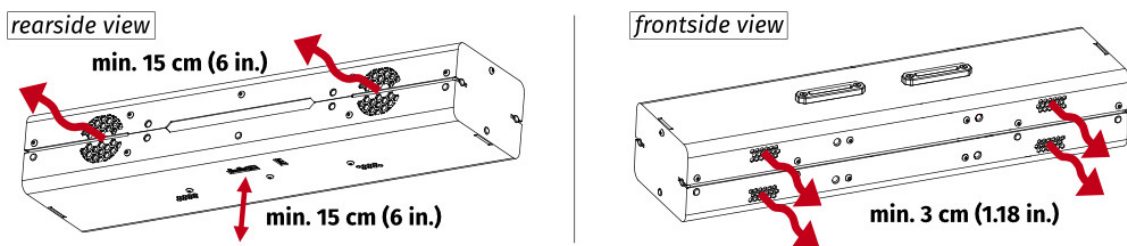

4.4. DIMENSIONS AND WEIGHT

QS-BT1 MAIN UNIT DIMENSIONS

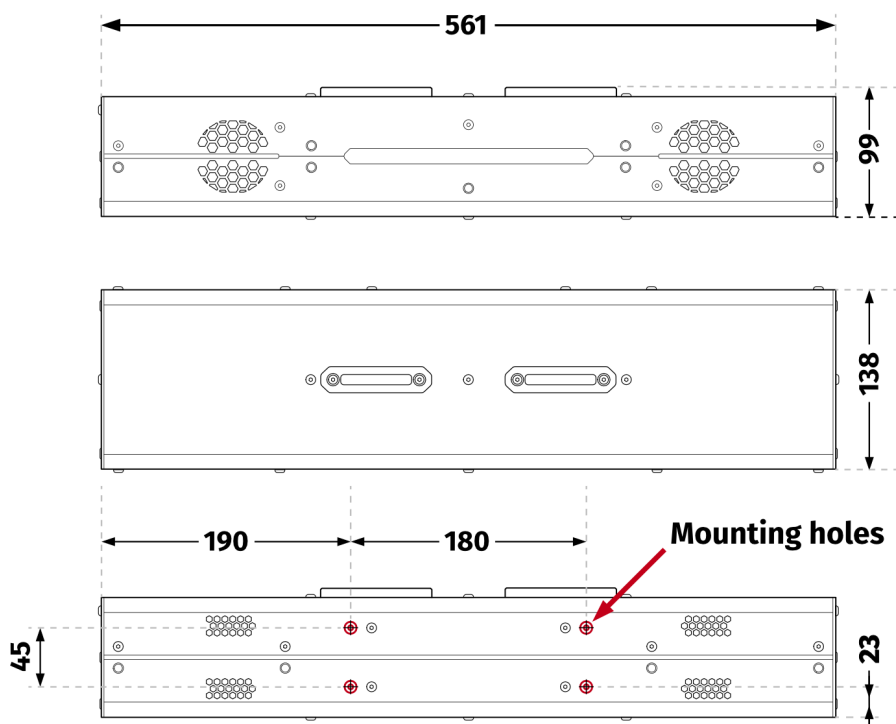

UNIVERSAL MOUNTING ADAPTER DIMENSIONS

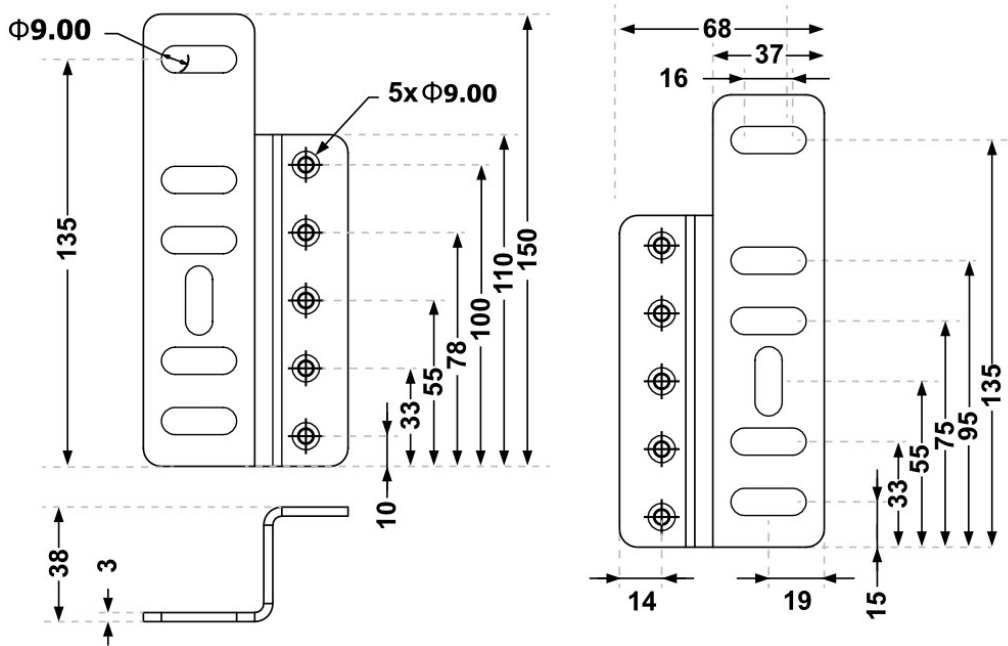

SEAT INSERTS DIMENSIONS

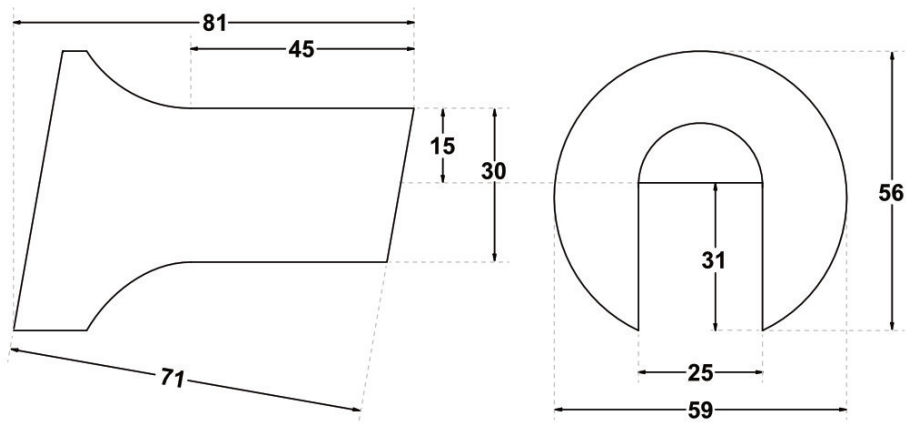

BELT BUCKLE DIMENSIONS

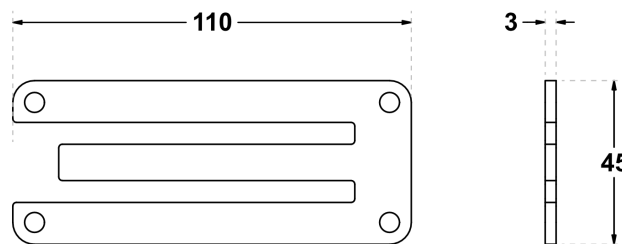

* ALL DIMENSIONS IN MILLIMETERS

QS-BT1'S WEIGHT

The QS-BT1 unit's weight is: **13 kg (28.66 lbs)** [without cockpit mounting adapters].

MOUNTING HOLE DIMENSIONS

The QS-BT1's mounting bolts insertion depth **CANNOT** exceed **20 mm** and **CANNOT** be less than **15 mm**.

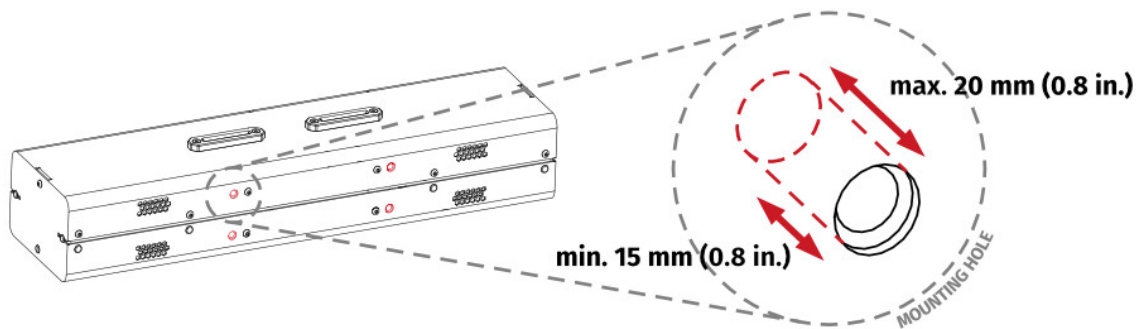

INCLUDED CABLES LENGTHS

- Power supply's integrated cable - 1.9 m (75 in.)
- Power cord for power supply - 1.8 m (71 in.)
- USB cable - 3 m (118 in.)
- Motion lock interlink cable - 2 m (79 in.)

4.5. POWER SUPPLY SPECIFICATION

QS-BT1 requires 120/230 VAC 50-60 Hz single phase power source with neutral and protective earth connection.

WARNING

The power supply for QS-BT1 includes an electric cord with an equipment-grounding conductor and a grounding plug. The plug must be plugged into a matching socket that is correctly installed and grounded in accordance with appropriate local codes and ordinances.

Applicable plugs for different regions:

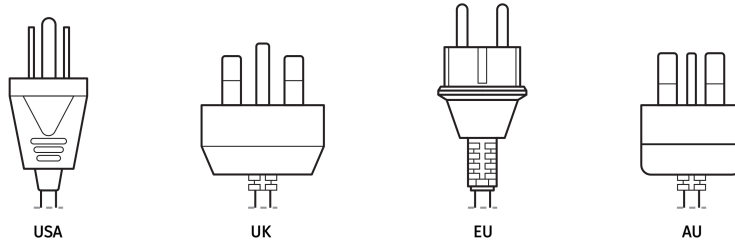

Check if the power cord plug has a grounding connection (with 3 pins). To reduce the risk of electric shock, **DO NOT** use the plug without a grounding connection (without a center pin).

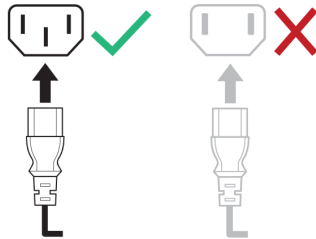

WARNING

This device is **NOT** intended to be used in an IT earthing/grounding system.

4.6. POWER REQUIREMENTS AND CONSUMPTION

Voltage [V]	Apparent Power*		Current Specification**	Power consumption	
	Average Power [VA]	Peak Power [VA]	Peak Current [A]	Average Power (stress test) [W]	Average Power (typical game) [W]
230	30	120	1.2	70	10
120	30	120	2.6	80	20

* For converter / UPS specification

** For circuit breaker specification

4.7. NOISE EMISSION

The QS-BT1 was checked for noise level emission. Noise level during normal work conditions is not over 50 dB. Measurements method complies with ISO 11202 standard. Four measuring positions as shown on the picture are placed 160 cm from the floor level and 100 cm from the edge of the device.

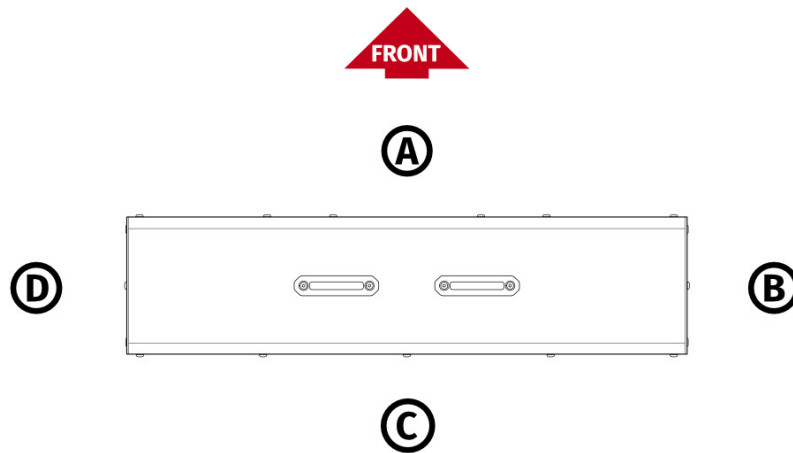

Measurement point	A	B	C	D
Measurement conditions: <ul style="list-style-type: none"> ■ Seat belt tensioned ■ 100% power ■ With power supply fan 	49,4 dB	49 dB	49 dB	49,1 dB
<ul style="list-style-type: none"> ■ Seat belt tensioned ■ 100% power ■ Without power supply fan 	44,6 dB	47 dB	48 dB	42 dB

5. SETUP AND INSTALLATION

5.1. ATTACHING TO THE ALUMINUM BASED COCKPIT PROFILE

If you have a custom cockpit based on aluminum profiles, QS-BT1 must be mounted using universal mounting adapters.

Assembly parts included with QS-BT1:

No.	Part description	Qty.
1	Universal mounting adapter	2
2	T-slot nut M8	4
3	Bolt M8 x 16 (DIN 933)	4
4	Washer A8,4 (DIN 125)	8
5	Bolt M8 x 40 (DIN 913)	4
6	Nut M8 (DIN 985)	4

INFO

Illustration of a finished assembly with a sample aluminum based cockpit profile.

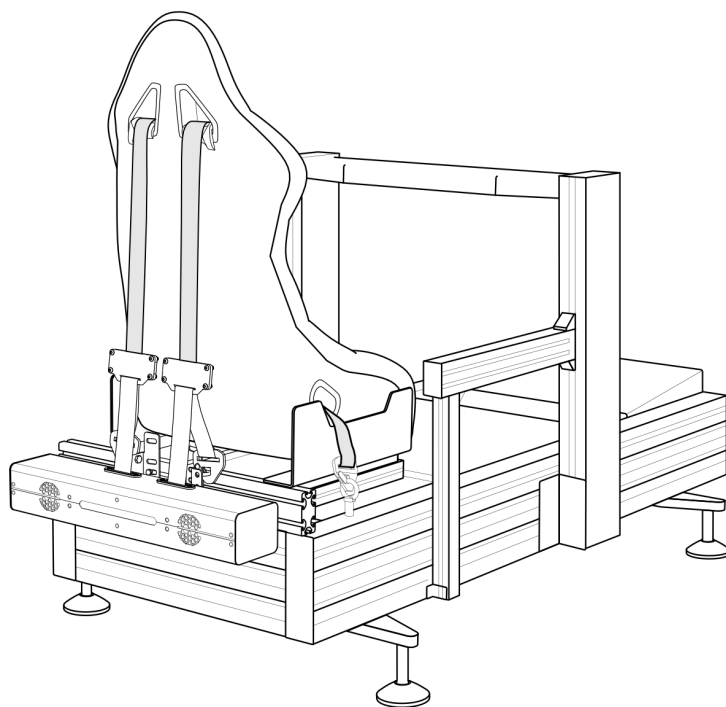

WARNING

Ensure that your cockpit construction and attachment points can withstand forces generated by the device. The maximum generated force is 200 N on each belt.

WARNING

In case of motion platform implemented cockpits - the QS-BT1 always **MUST BE** mounted to a position that is moving along with the seat.

Seat belts must always be tightened in order for QS-BT1 to work correctly.

INFO

Before installing the QS-BT1 to a cockpit - write down Serial Number which is located on the underside of the device. Refer to section 6.2 on page 47 for details. Serial Number is also available on the side of packaging box.

1. Slide the T-Slot nuts (they can also be inserted directly into the T-slot nut channel at any spot) into the cockpit rear profile bar and then screw in the universal adapter using bolts and washers by hand. Do not torque down the bolts yet.

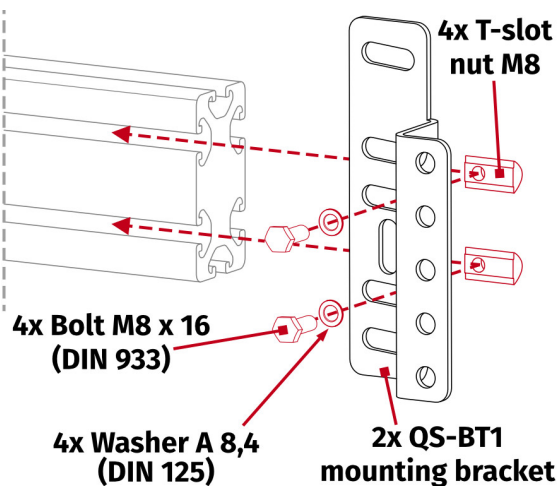

2. Adjust the space between mounting brackets to match the belt tensioner mounting holes.

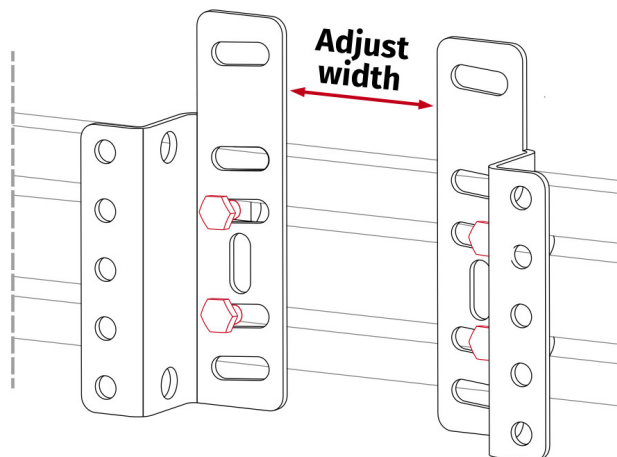

3. Screw in included bolts into the QS-BT1 (hex key for DIN 913 bolts is not included). Do not overtorque them - maximum 10 Nm (7.4 ft-lbs) of torque.

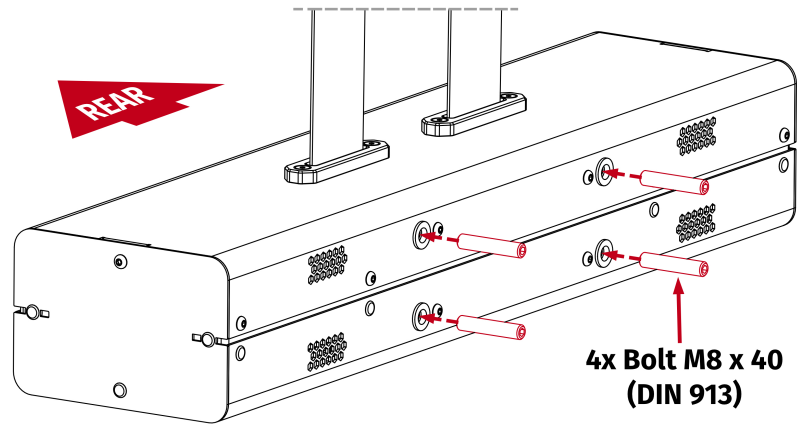

4. Attach the QS-BT1 to mounting brackets.

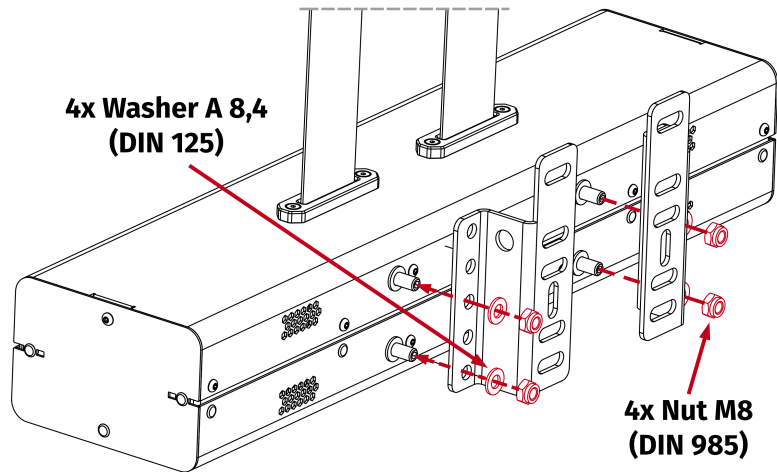

5. Torque down bolts and nuts.

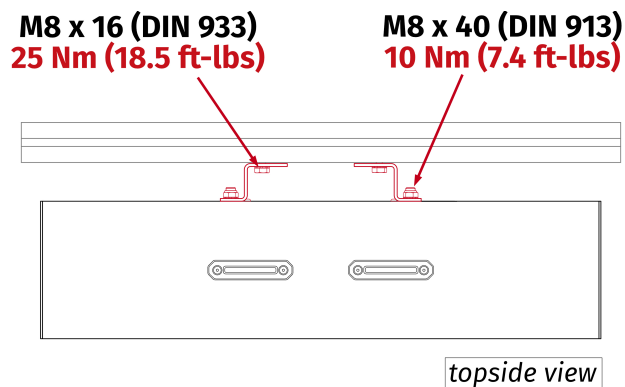

WARNING

A device running with incorrectly tightened bolts is dangerous to a user and will cause irreversible damage to the hardware and mounting points.

INFO

Revision B of QS-BT1 is using different mounting hardware:

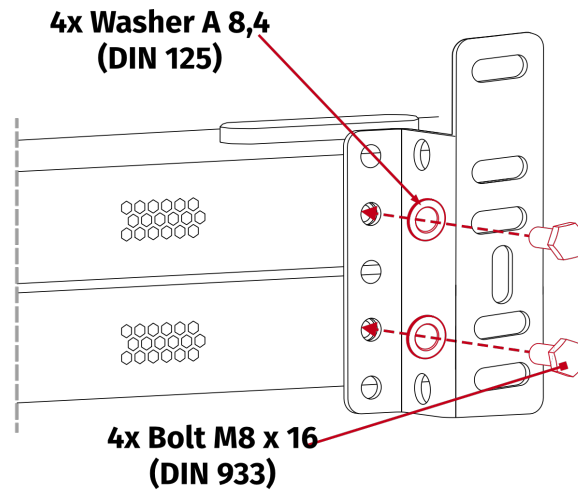

5.2. ATTACHING TO QS-CH1

The QS-BT1 should be attached to QS-CH1 using two mounting brackets (not included - can be purchased separately from our retailers).

Assembly parts included with QS-BT1:

No.	Part description	Qty.
1	Bolt M8 x 40 (DIN 913)	4
2	Nut M8 (DIN 985)	4
3	Washer A8,4 (DIN 125)	4

Assembly parts included with QS-CH1 mounting brackets:

No.	Part description	Qty.
1	Mounting brackets	2

INFO

Illustration of a finished assembly.

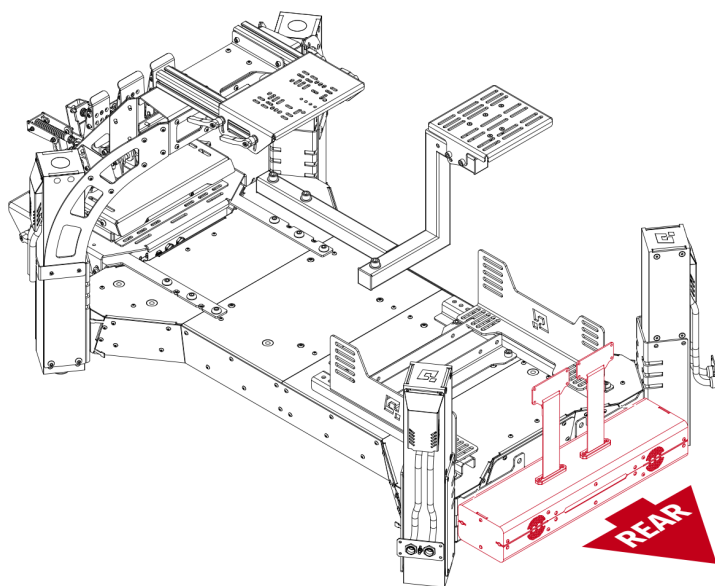

INFO

Before installing the QS-BT1 to a cockpit - write down Serial Number which is located on the underside of the device. Refer to section 6.2 on page 47 for details. Serial Number is also available on the side of packaging box.

INFO

Mounting brackets are **NOT** interchangeable. Metal lip must be at the bottom.

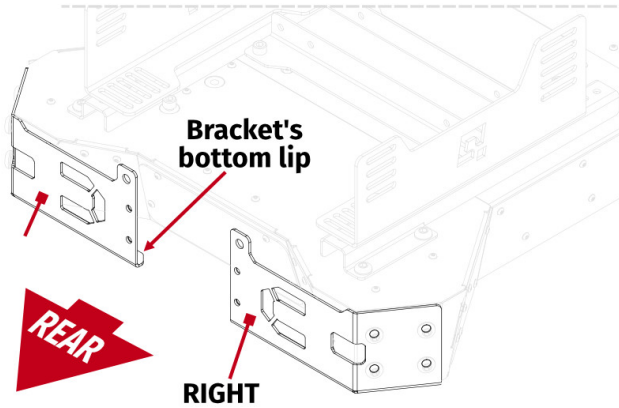

1. Unscrew QS-210/220's back actuators. Attach the QS-BT1 mounting bracket between the device's base and the actuator mounting bracket. Tighten all QS-210/220's four bolts to **25 Nm (18.5 ft-lbs)** of torque.

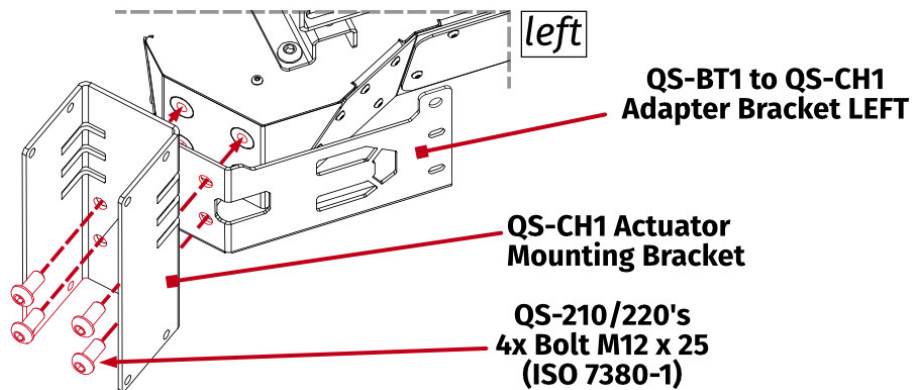

2. Repeat the operation on the other side.

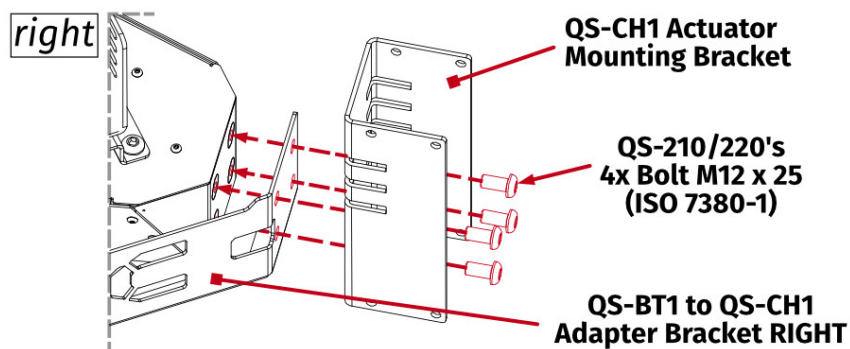

3. Screw in included bolts into the QS-BT1 (hex key for DIN 913 bolts is not included). Do not overtorque them - maximum 10 Nm (7.4 ft-lbs) of torque.

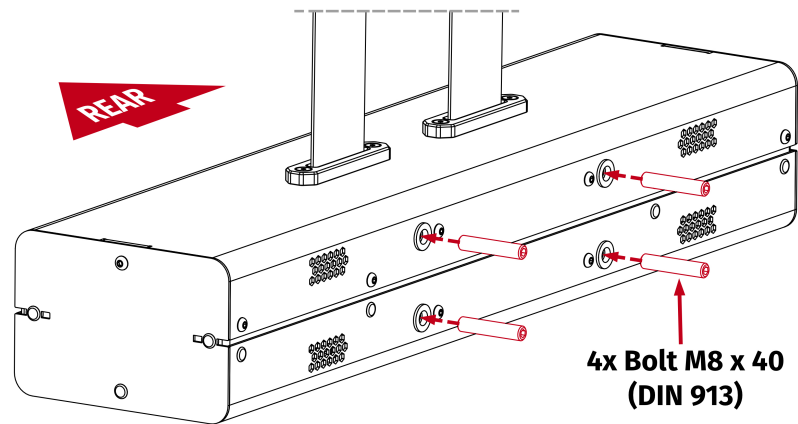

4. Attach the QS-BT1 to mounting brackets.

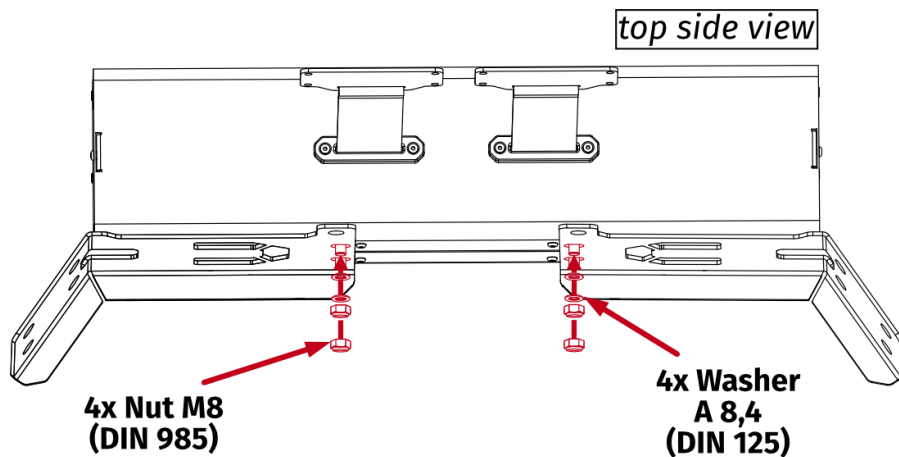

5. Attach the actuators back to their brackets. For details, refer to [QS-CH1 user manual](#).

INFO

Revision B of QS-BT1 is using different mounting hardware:

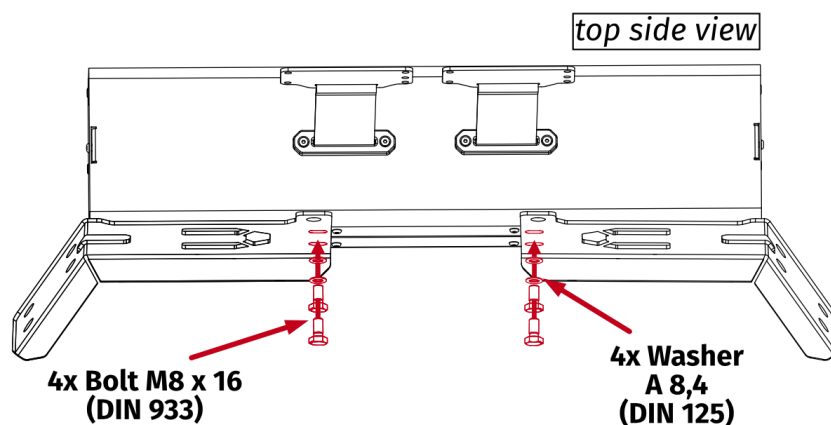

5.3. ATTACHING TO QS-V20

The QS-BT1 should be attached to QS-V20 using a mounting bracket (not included - can be purchased separately from our retailers).

Assembly parts included with QS-BT1:

No.	Part description	Qty.
1	Bolt M8 x 40 (DIN 913)	4
2	Nut M8 (DIN 985)	4
3	Washer A8,4 (DIN 125)	4

Assembly parts included with QS-V20 mounting bracket:

No.	Part description	Qty.
1	Mounting bracket	1
2	Bolt M8 x 25 (DIN 912)	4
3	Nut M8 (DIN 985)	2
4	Washer A 8,4 (DIN 125)	2

INFO

Illustration of a finished assembly.

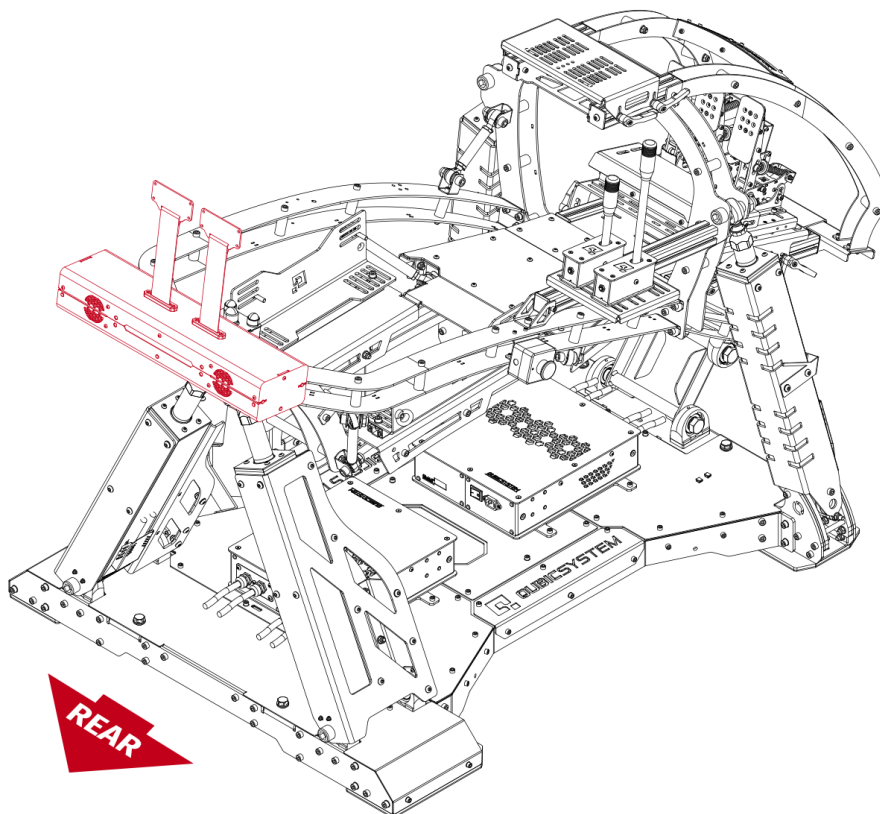

INFO

Before installing the QS-BT1 to a cockpit - write down the Serial Number which is located on the underside of the device. Refer to section **6.2** on page **47** for details. Serial Number is also available on the side of packaging box.

- 1. OPTIONAL for easier access** - unscrew the rear logo plate (in case of rivets using assembly - drill them out).

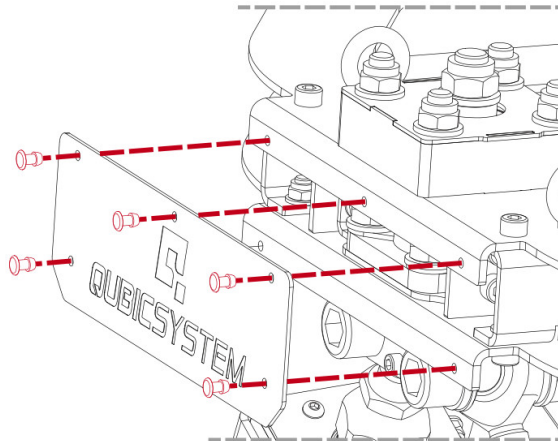

- 2. Unscrew the bolts and eye-ring nuts from the QS-V20's frame.**

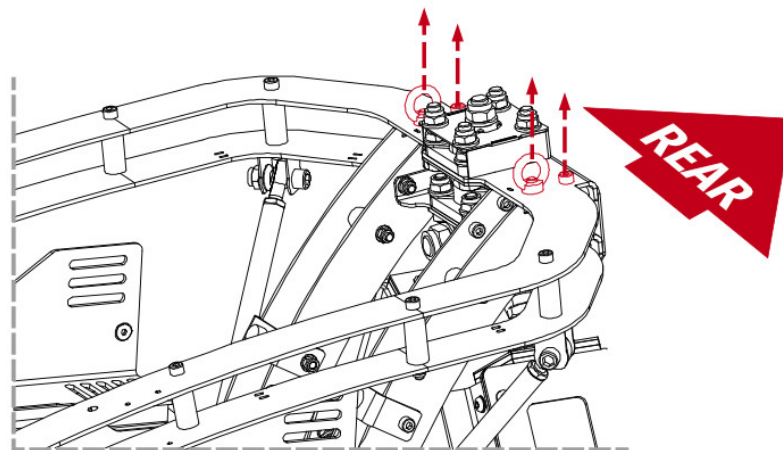

- Rest the bracket flat on the QS-V20 frame and put through back mounting bolts from the top. Screw on eye-ring nuts on the front bolts that were inserted from the bottom.

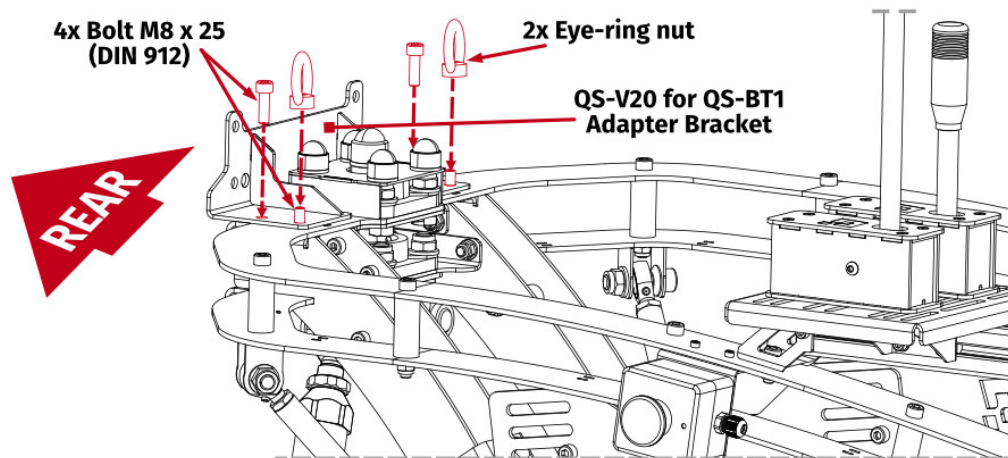

- Screw nuts on the back bolts from underneath. Torque down all four bolts to **25 Nm (18.5 ft-lbs)** of torque while holding two nuts from underneath with a flat wrench and eye-rings from the top.

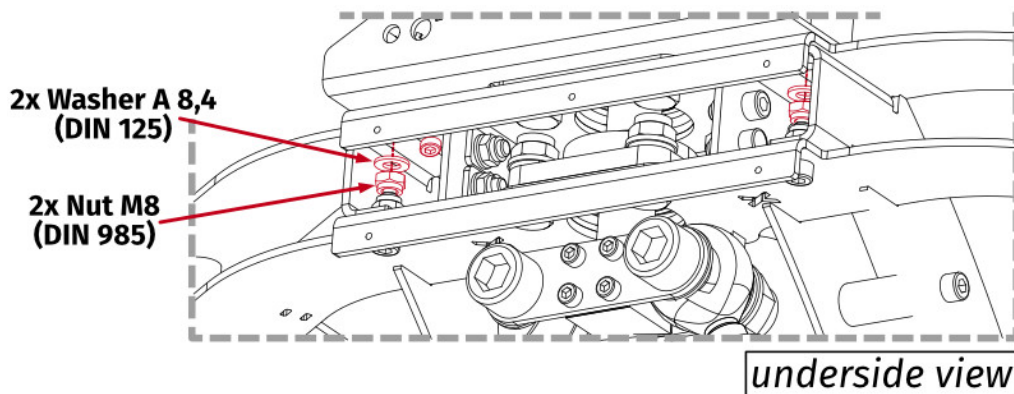

- Screw in included bolts into the QS-BT1 (hex key for DIN 913 bolts is not included). Do not overtorque them - maximum 10 Nm (7.4 ft-lbs) of torque.

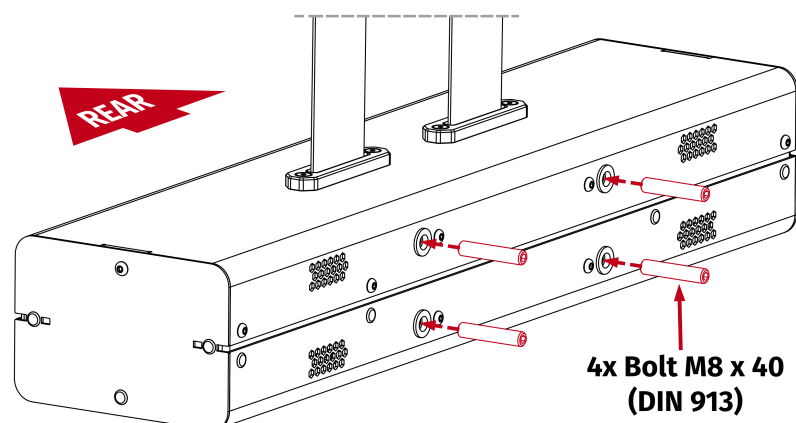

6. Attach the QS-BT1 to mounting brackets.

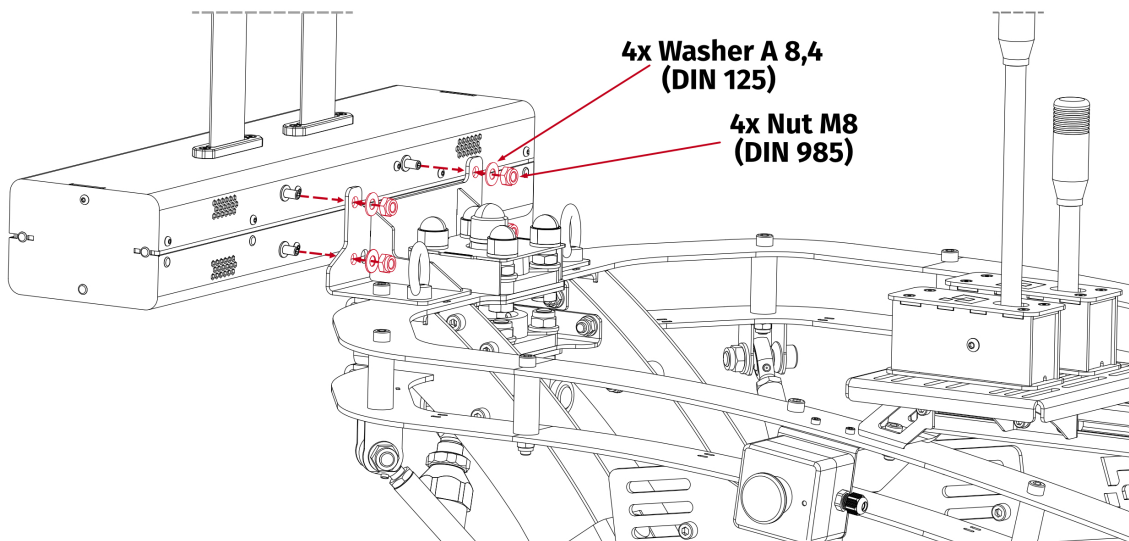

7. OPTIONAL - mount the logo plate back on. In case of rivets using assembly use a rivet gun with 4.8 mm x 10 mm blind rivets.

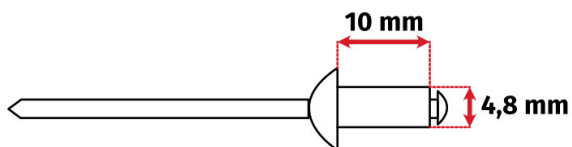

INFO

Revision B of QS-BT1 is using different mounting hardware:

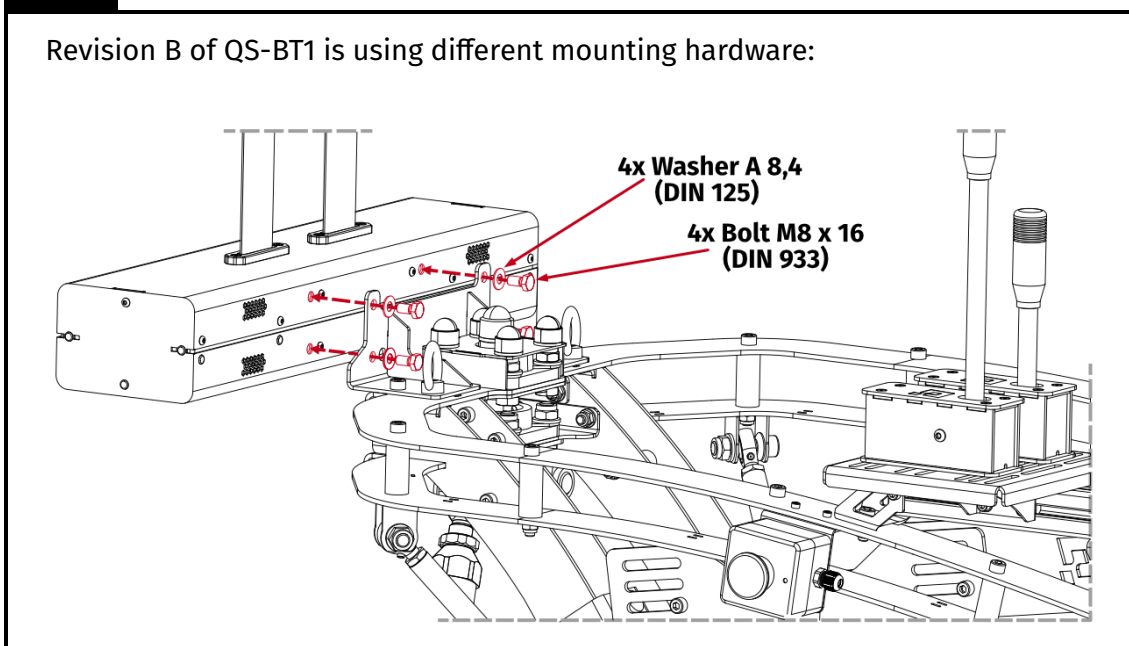

5.4. ATTACHING TO QS-S25

The QS-BT1 should be attached to the QS-S25 using a mounting bracket (not included - can be purchased separately from our retailers).

Assembly parts included with QS-BT1:

No.	Part description	Qty.
1	Bolt M8 x 40 (DIN 913)	4
2	Nut M8 (DIN 985)	4
3	Washer A8,4 (DIN 125)	4

Assembly parts included with QS-S25 mounting bracket:

No.	Part description	Qty.
1	Mounting bracket	1
2	Bolt M8 x 35 (DIN 912)	4
3	Nut M8 (DIN 985)	4
4	Washer A 8,4 (DIN 125)	4

INFO

Illustration of a finished assembly.

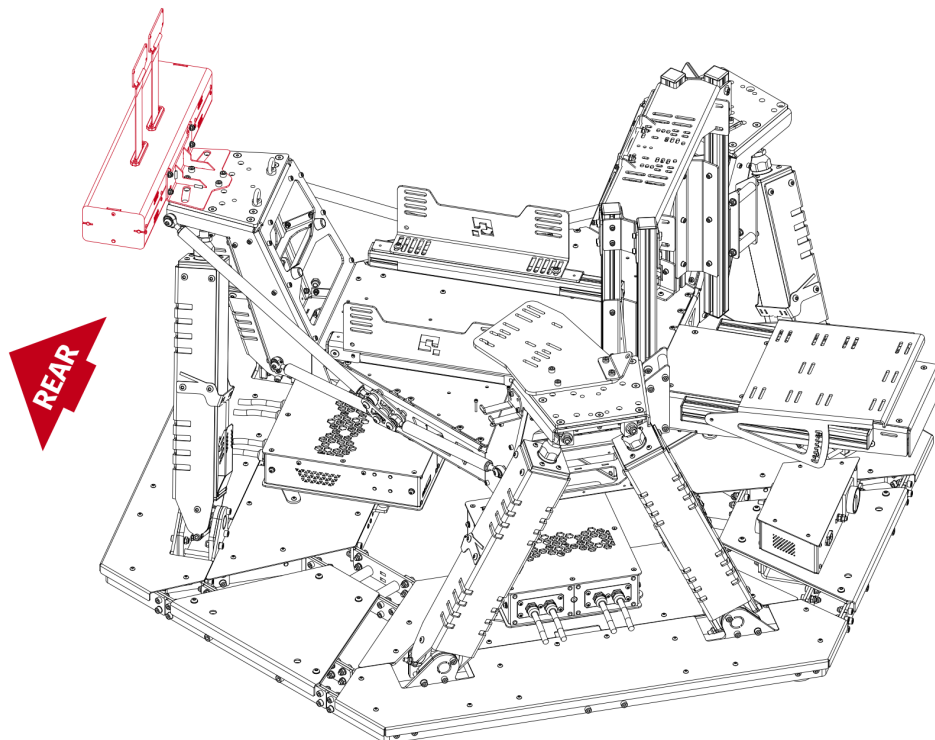

INFO

Before installing the QS-BT1 to a cockpit - write down Serial Number which is located on the underside of the device. Refer to section **6.2** on page **47** for details. Serial Number is also available on the side of packaging box.

1. Attach the QS-BT1 bracket to the back of QS-S25 frame. Rest the bracket flat on the QS-S25 frame and put through mounting bolts. Screw in the nuts on the bolts from underneath. Torque down all four bolts to **25 Nm (18.5 ft-lbs)** of torque while holding the nuts from underneath with a flat wrench.

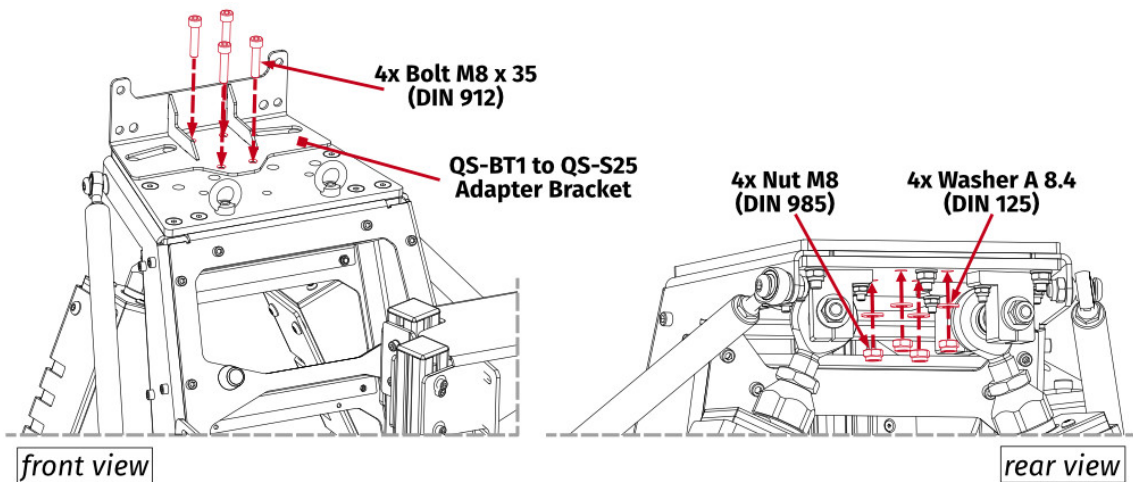

2. Screw in included bolts into the QS-BT1 (hex key for DIN 913 bolts is not included). Do not overtorque them - maximum 10 Nm (7.4 ft-lbs) of torque.

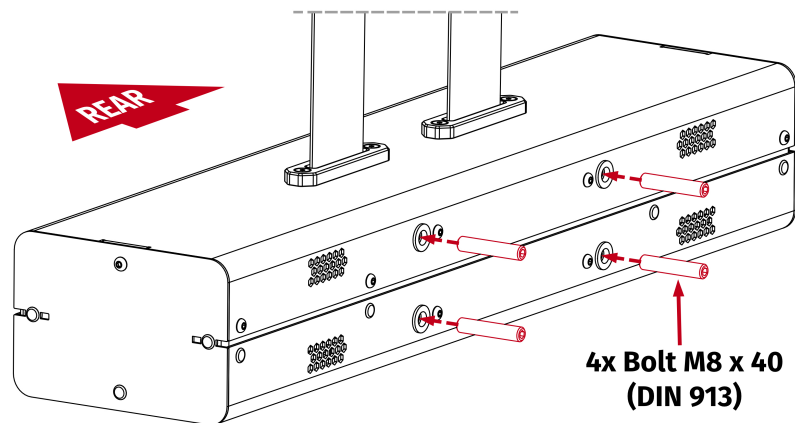

3. Attach the QS-BT1 to mounting brackets.

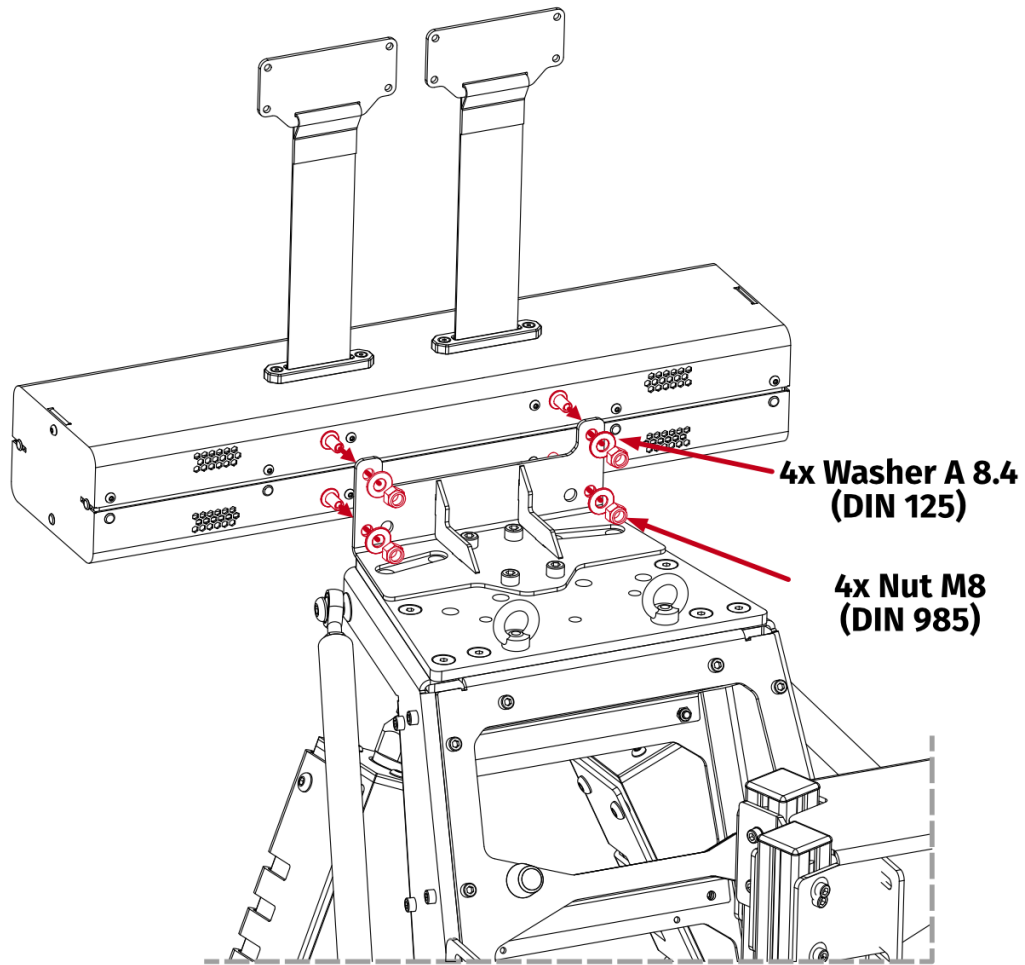

INFO

Revision B of QS-BT1 is using different mounting hardware:

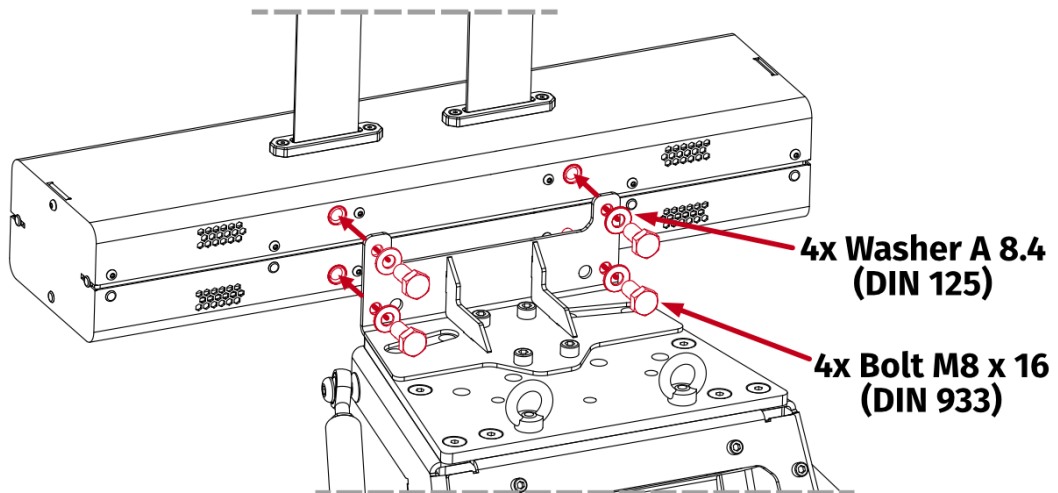

5.5. ATTACHING TO NEXT LEVEL RACING MOTION PLATFORM V3

WARNING

- **DO NOT** attach QS-BT1 to the platform cockpit. Belt tensioner **MUST** be attached to a mobile top frame of the NLR Motion Platform V3 unit.
- You **CANNOT** use QS-BT1 with standard Butt kicker Gamer 2 bracket.
- Adding QS-BT1 reduces maximum user weight for NLR Motion Platform V3 down to 115 kg (253 lbs).

The QS-BT1 should be attached to NLR Motion Platform V3 using two mounting brackets (not included - can be purchased separately from our retailers).

Assembly parts included with QS-BT1:

No.	Part description	Qty.
1	Bolt M8 x 40 (DIN 913)	4
2	Nut M8 (DIN 985)	4
3	Washer A8,4 (DIN 125)	4

Assembly parts included with NLR Motion Platform V3 mounting bracket:

No.	Part description	Qty.
1	Mounting bracket	2
2	Spacer	2
3	Bolt M8 x 55 (DIN 912)	2
4	Nut M8 (DIN 985)	6
5	Washer A 8,4 (DIN 125)	6
6	Bolt M8 x 25 (DIN 912)	4

INFO

Adapting brackets are not interchangeable. Refer to illustration below.

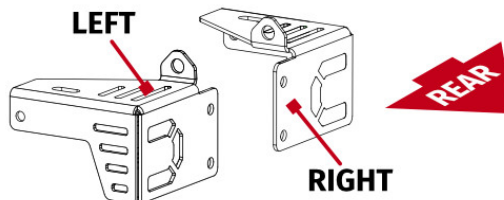

INFO

Before installing the QS-BT1 to a cockpit - write down Serial Number which is located on the underside of the device. Refer to section 6.2 on page 47 for details. Serial Number is also available on the side of packaging box.

INFO

Illustration of a finished assembly with a sample cockpit.

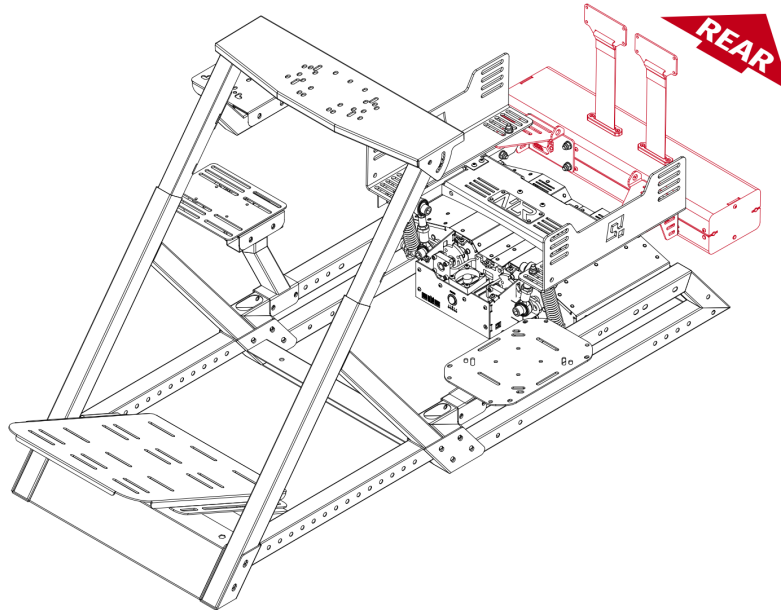

1. Remove the seat from seat adapter bracket.
2. Attach the QS-BT1 mounting bracket and spacer between the top frame of the NLR Motion Platform V3 motion unit and the seat mounting bracket.

INFO

The seat adapter bracket in the illustrations below serves only as an example. The QS-BT1's adapter brackets must be attached to your seat adapter/seat rails.

leftside view

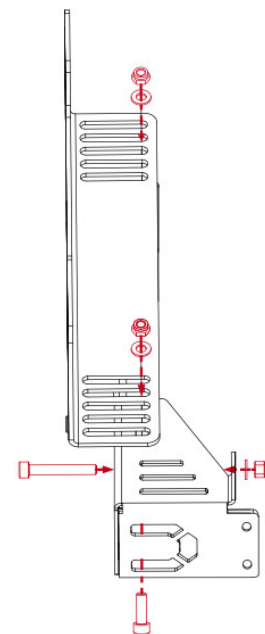
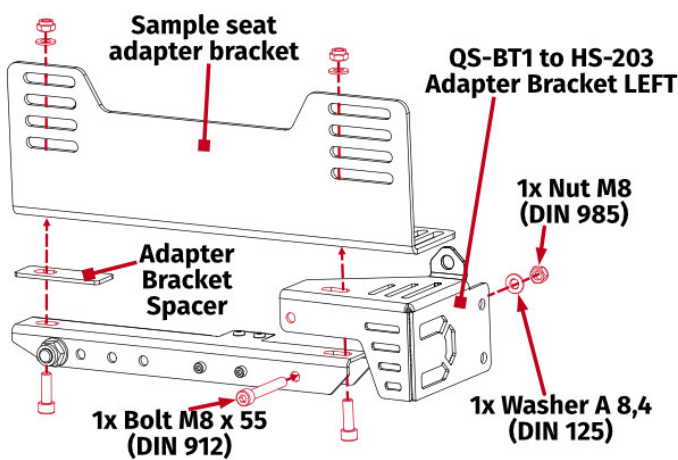

3. Attach the seat mounting bracket to the top frame of NLR Motion Platform V3 motion unit. Tighten M8x25 bolts to **25 Nm (18.5 ft-lbs)** and M8x55 bolts to **20 Nm (14.7 ft-lbs)** of torque while holding the nuts with a flat wrench.

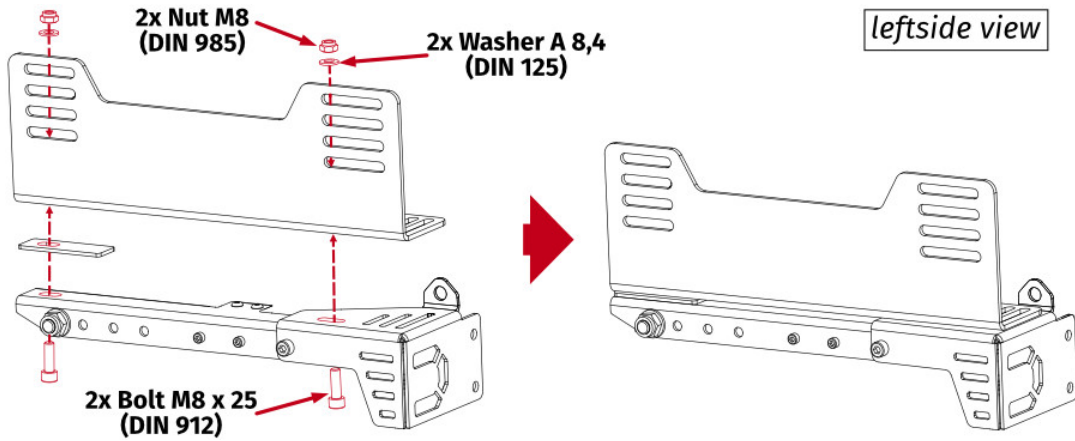

4. Screw in included bolts into the QS-BT1 (hex key for DIN 913 bolts is not included). Do not overtorque them - maximum 10 Nm (7.4 ft-lbs) of torque.

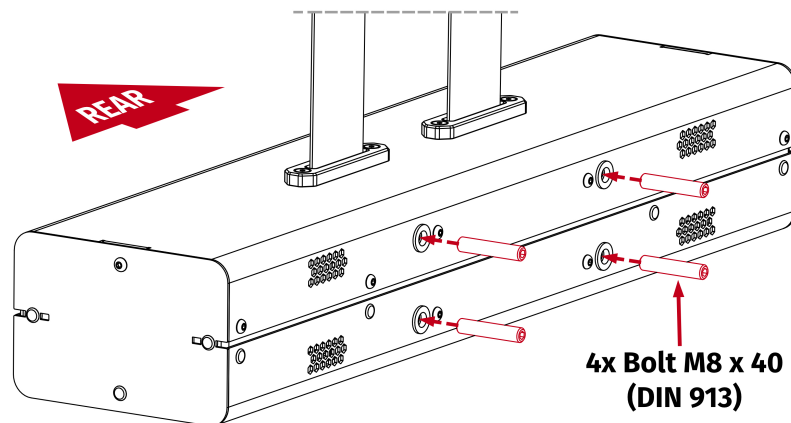

5. Attach the QS-BT1 to mounting brackets.

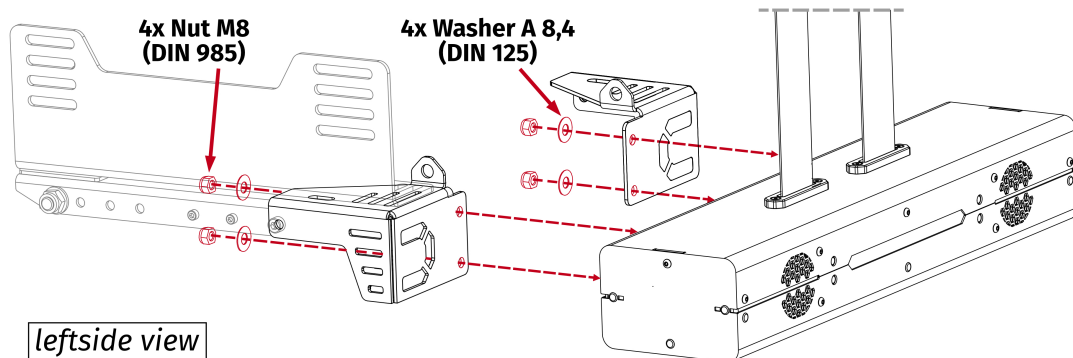

INFO

Revision B of QS-BT1 is using different mounting hardware:

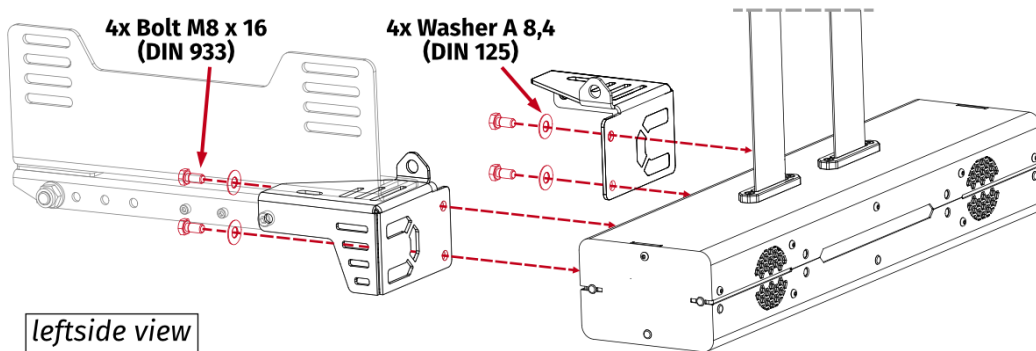

5.6. BELT INSTALLATION

5.6.1 ATTACHING HARNESS TO THE PLATFORM

INFO

- Attaching harness to the platform (with snap-hooks or a shackle) is highly **recommended**. The QS-BT1 should only work as a belt tensioner, not a belt's hooking point.
- **First** - attach the harness to a cockpit and adjust it for the user (section 5.7.1 on page 38), **second** - attach tensioner buckles to the harness.

WARNING

All operations **MUST** be performed with the power OFF.

1. Universal adapter bracket

Mount eye-ring nuts to the QS-BT1's mounting bracket (hardware not included). Then attach the seat belt's snap hooks to the eye-ring nuts.

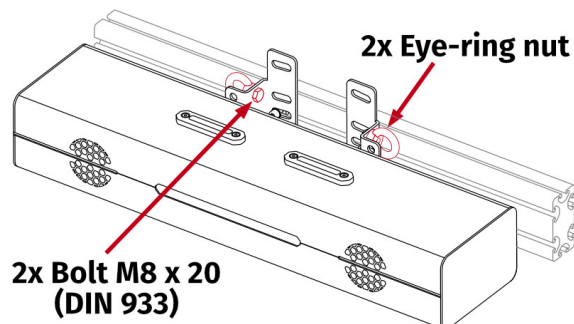

2. QS-CH1

Mount eye-ring nuts to the QS-BT1's mounting bracket (hardware not included). Then attach the seat belt's snap hooks to the eye-ring nuts.

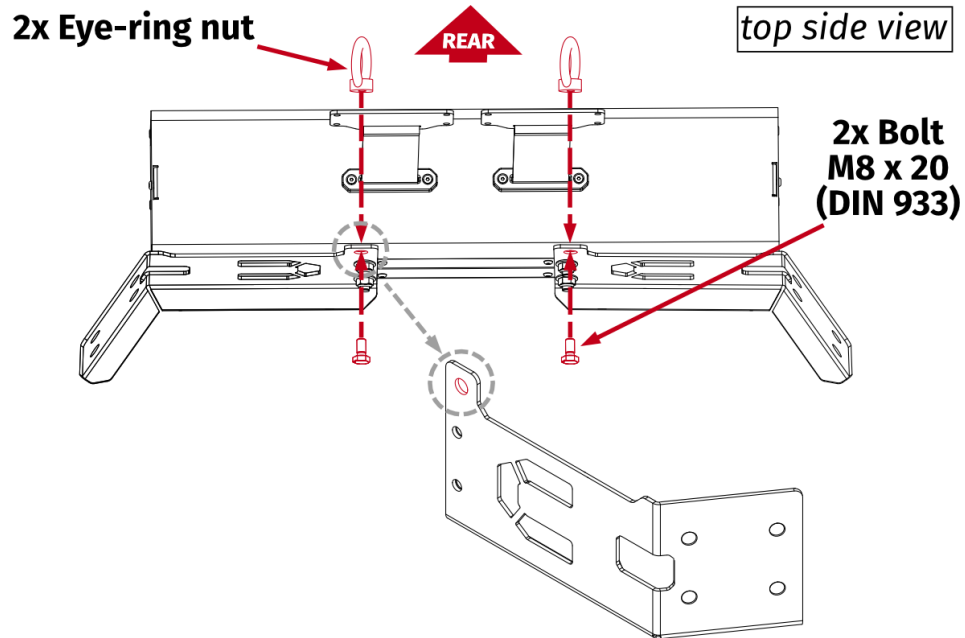

3. QS-V20

Attach the seat belt's snap hooks to the eye-ring nuts. Eye-ring nuts are equipped from factory.

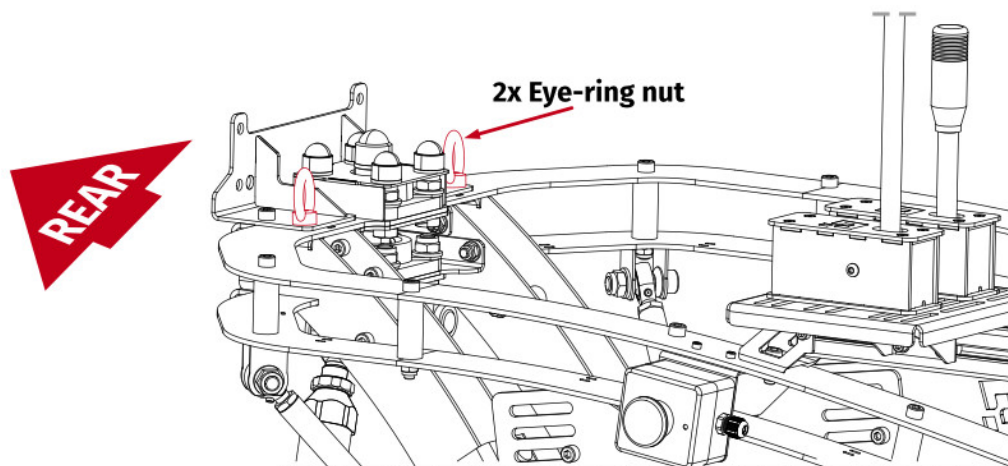

4. QS-S25

Attach the seat belt's snap hooks to the eye-ring nuts. Eye-ring nuts are equipped from factory.

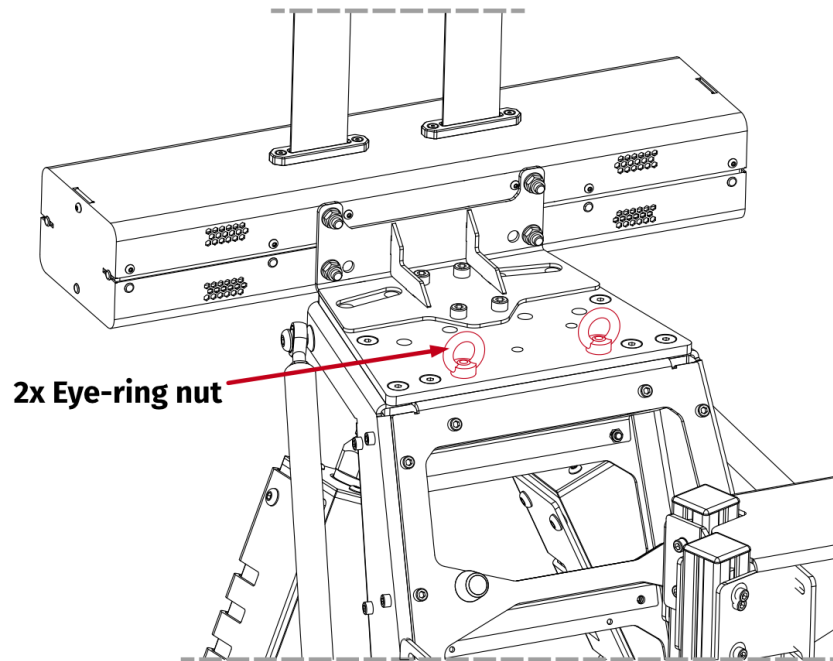

5. Next Level Racing Motion Platform V3

Mount eye-ring nuts to the QS-BT1's mounting bracket (hardware not included). Then attach the seat belt's snap hooks to the eye-ring nuts.

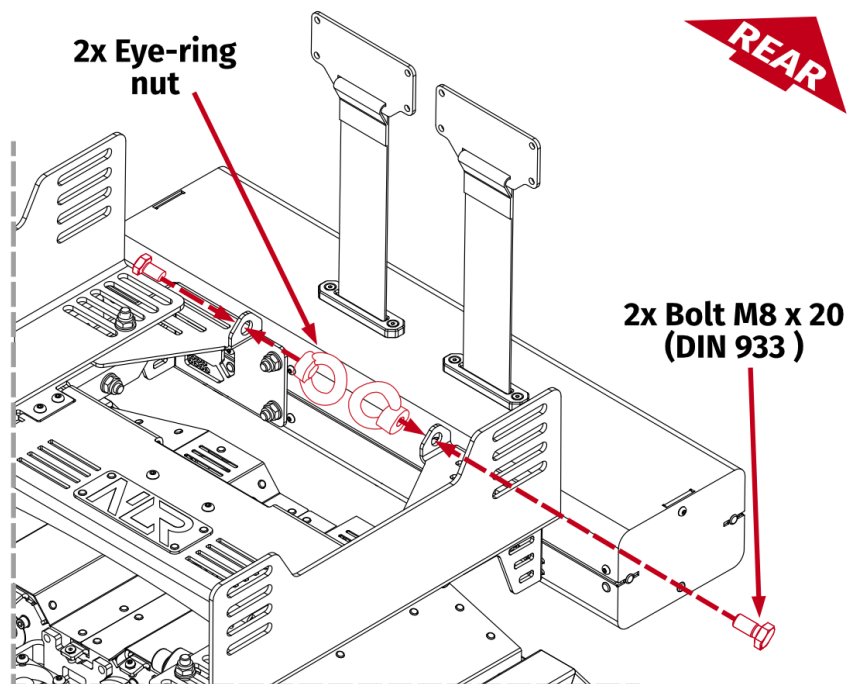

5.6.2 ATTACHING TENSIONER BUCKLES TO THE HARNESS

QS-BT1's Tensioner Buckles should be mounted to your seat belts (harness) using included Belt buckles and fasteners. Use seat inserts for the holes in your racing seat.

Assembly parts included with QS-BT1:

No.	Part description	Qty.
1	Belt buckle	2
2	Bolt M5 x 12 (ISO 7380-1)	10
3	Nut M5 (DIN 986)	10
4	Washer A 5,3 (DIN 125)	10
5	Seat inserts (interchangeable)	2
6	Velcro strips	2 x 2

INFO

Illustration of a finished belt buckles assembly.

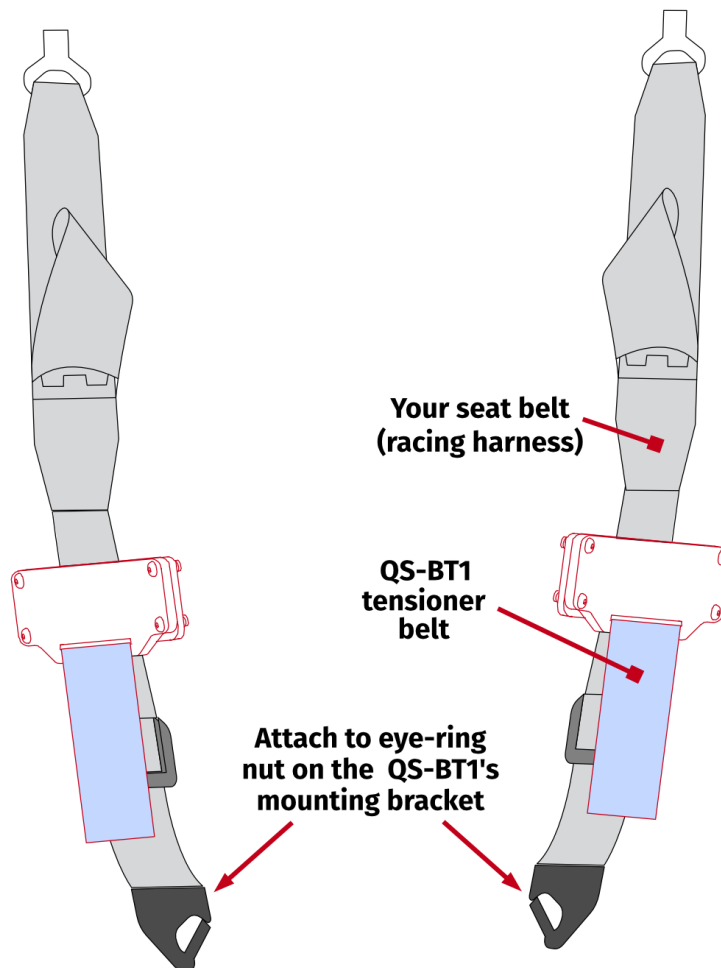

INFO

QS-BT1 is shipped with the built-in belts rolled inside. They **MUST BE** manually fully extended **before installation** - otherwise it will affect the tensioning force and therefore reduce the immersion. The belts when fully extended are 240 mm long (340 mm for revision B).

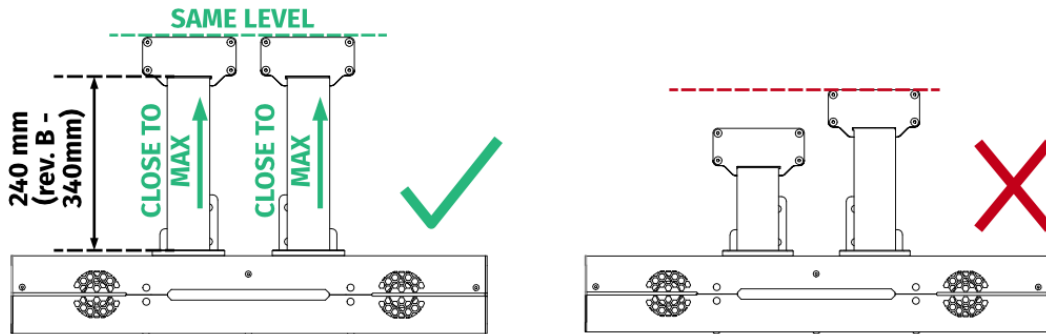

When reinstalling a previously used device, ensure that the belts are correctly extended:

1. Launch QubicManager and select **Tools and Diagnostic** → **Seat Belt Tensioner Diagnostic**
2. Make sure all of the sliders are at 0.00% (all the way to the left).

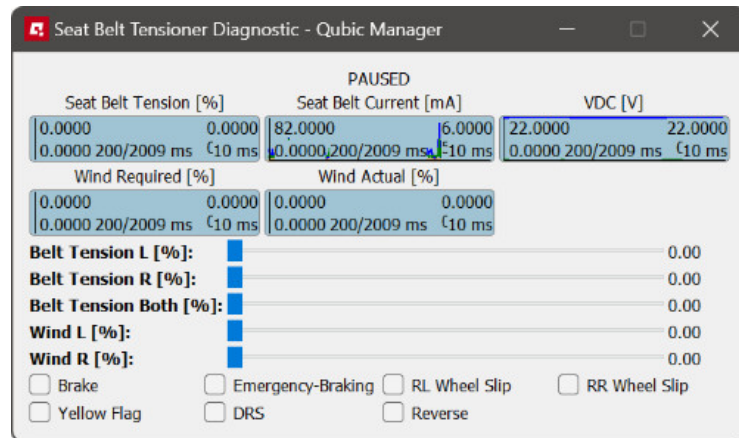

3. Manually fully extend the belts.

WARNING

All operations **MUST** be performed with the power OFF.

INFO

First - attach the harness to a cockpit and adjust it for the user (section 5.7.1 on page 38), **second** - attach tensioner buckles to the harness.

Installation:

1. Run your seat belt through the belt buckle and mount it with QS-BT1's tensioner buckle. Start from screwing in top bolts, then proceed to the ones below. Ensure they are perpendicular to the belt.

Belts should not have too much slack initially - before screwing the bolts down ensure proper tightening of the belts. They will be tensioned later by the QS-BT1 after in-game engagement (for more details go to section 7 on page 51).

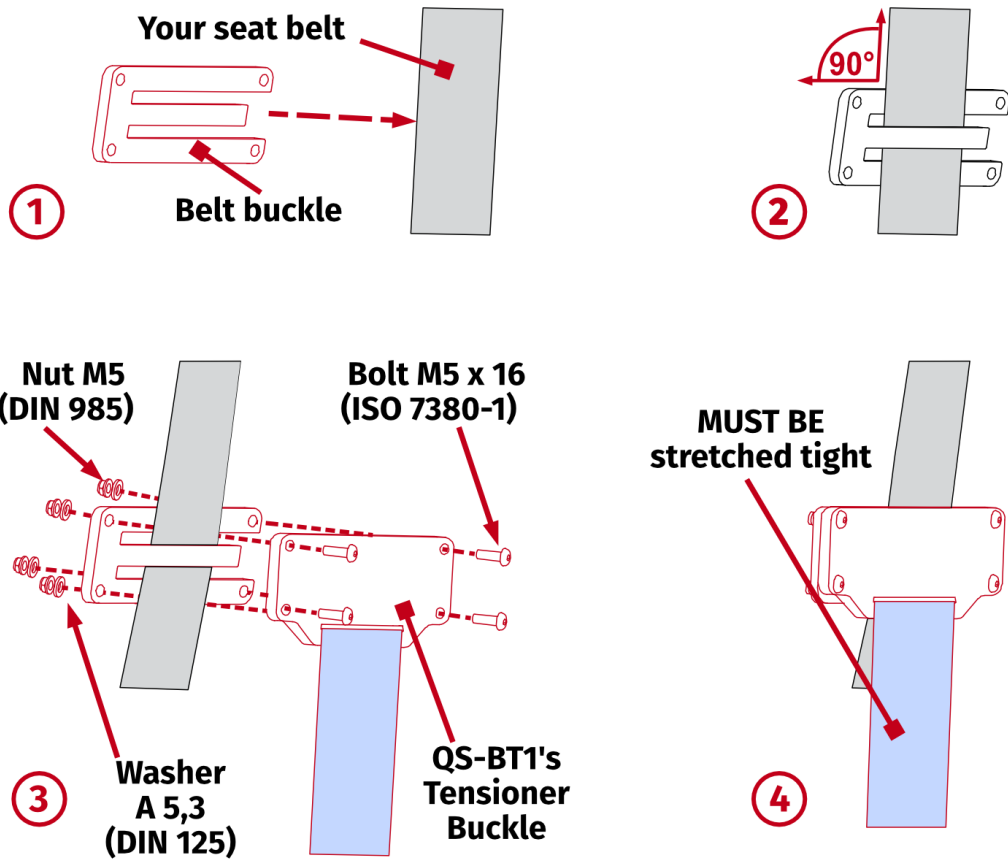

- Ensure correct mounting of the tensioner and belt buckles as this may have negative impact on device's performance and user's feeling of immersion.
- The belt tensioner generates a maximum of 200 N of force on each side. Install adjustable seat belts that can withstand forces generated by the device, preferably with FIA certification.

INFO

Revision B of the QS-BT1 is using 5 (instead of 4) assembling bolts and different type of belt buckle (with different assembly hardware):

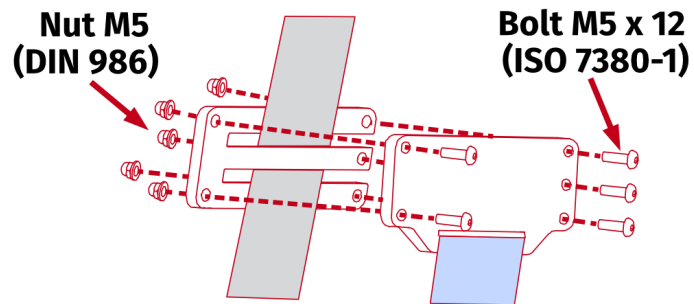

- **Preferably** - QS-BT1's Tensioner Buckles should be mounted on the same level and evenly in relation to each other - parallel to the QS-BT1's main unit.

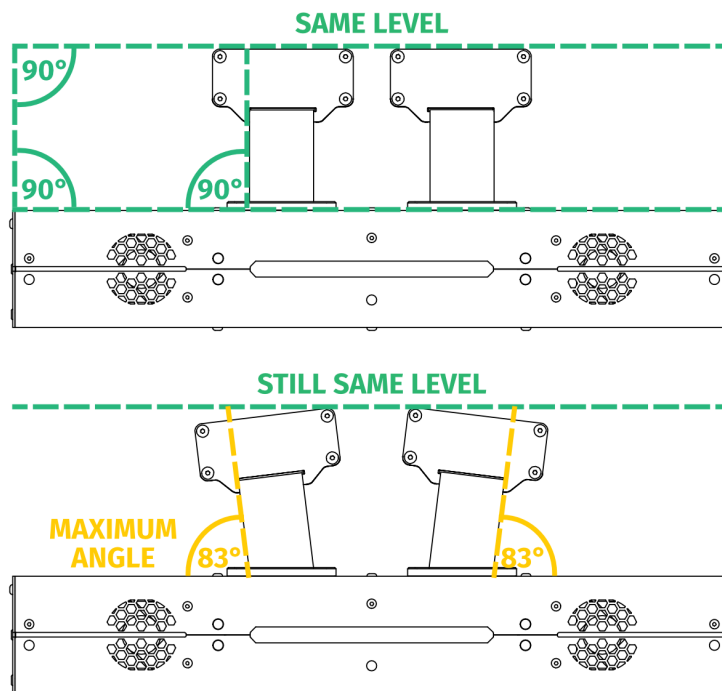

- If necessary, the device can be installed further away. Preferably the assembling method would ensure that the belts are perpendicular to the device. If necessary - maximum angle of belt inclination is 45 degrees.

If the belts rub against the housing while in normal operation - the pulling force will significantly drop, reducing the immersion.

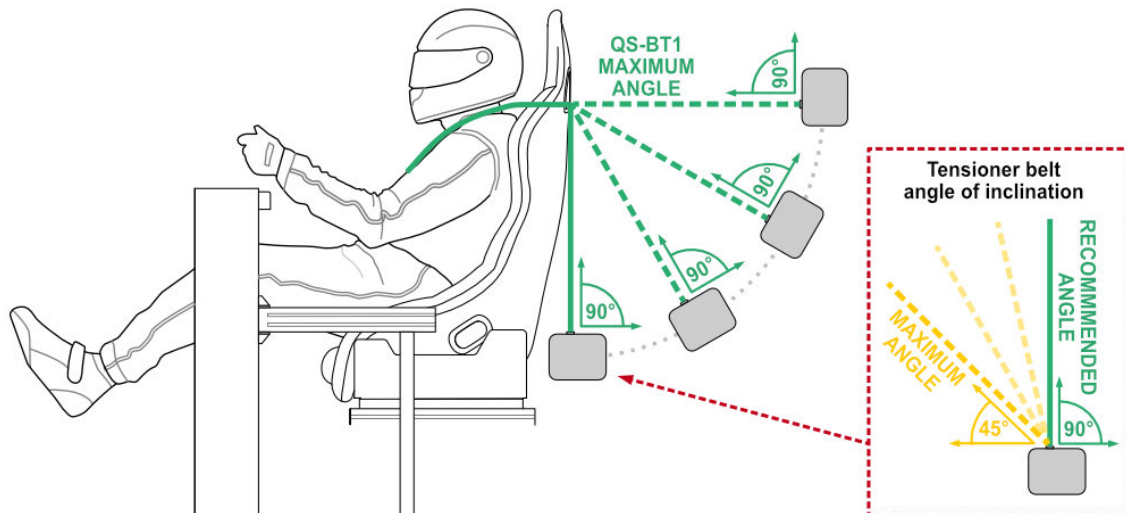

WARNING

In case of motion platform implemented cockpits - the QS-BT1 always **MUST BE** mounted to a position that is moving along with the seat.

In order for QS-BT1 to work correctly it is recommended that it always is mounted directly to a cockpit and not separately.

- Excess seat belt should be rolled and attached permanently to rest of the harness. It cannot interfere with platform movement.

5.6.3 SEAT INSERTS

INFO

Seat inserts are provided with the QS-BT1 mainly for better belt stability. They also keep your race seat from getting worn down and are a low friction attachment to reduce the sound of harness rubbing against the seat.

Check if the seat inserts fit your race seat's shoulder harness slots. If so, apply self adhesive velcro strips (included) inside seat inserts and harness slots.

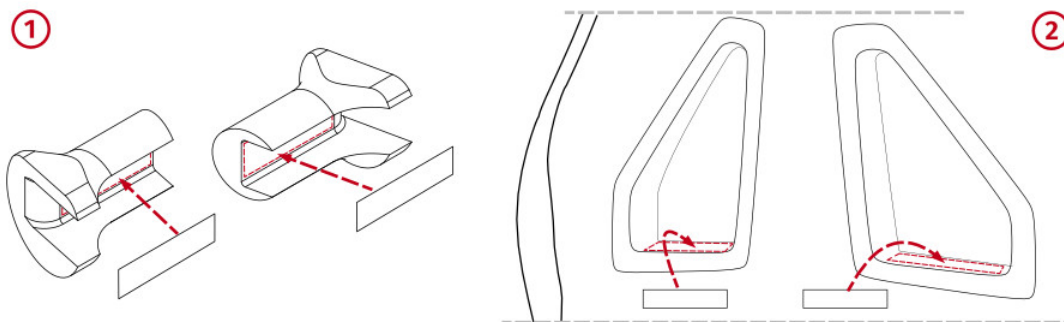

Attach seat insert inside race seat's shoulder harness slots. Inserts are identical and will fit interchangeably.

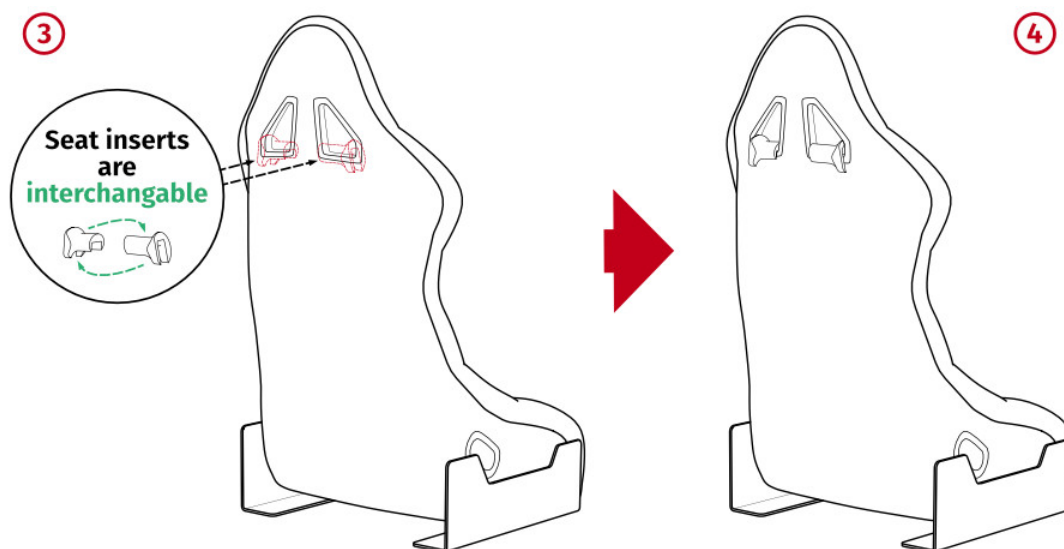

INFO

User may use an alternative solution for smooth harness operation, e.g. **after-market rollers**. However - minimum suggested roller diameter is no less than **35 mm**. Small diameter will cause bigger bend angle on the harness and will restrict tensioning force for the user, thus lowering the immersion.

5.7. SEAT BELT SETTINGS

5.7.1 SEAT BELT SETUP

For your comfort and the best simulation experience, the seat belt must be set up correctly (racing harness not included).

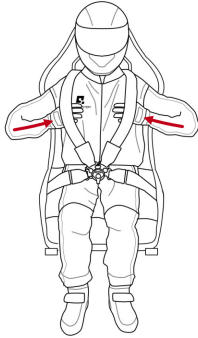

1. Correct seat belt tension can be determined by **placing your hands underneath the belts**. If your hands can move freely - tighten the belt. If you cannot put your hands under the belt - loosen the belt.

2. **All tongues** of the seat belt should be fastened to the buckle, as shown in the picture.

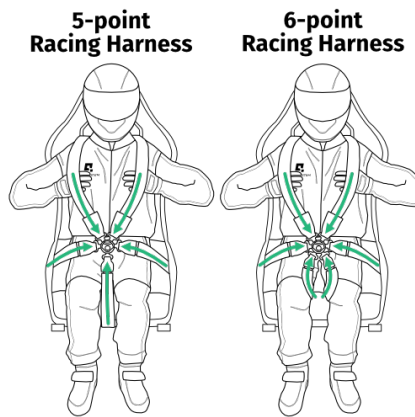

INFO

For the most realistic and immersive experience, seat belts should be horizontally positioned with **the same width as your neck width**. If the belts are positioned too wide or too narrow, pain or scratches in the neck area will occur.

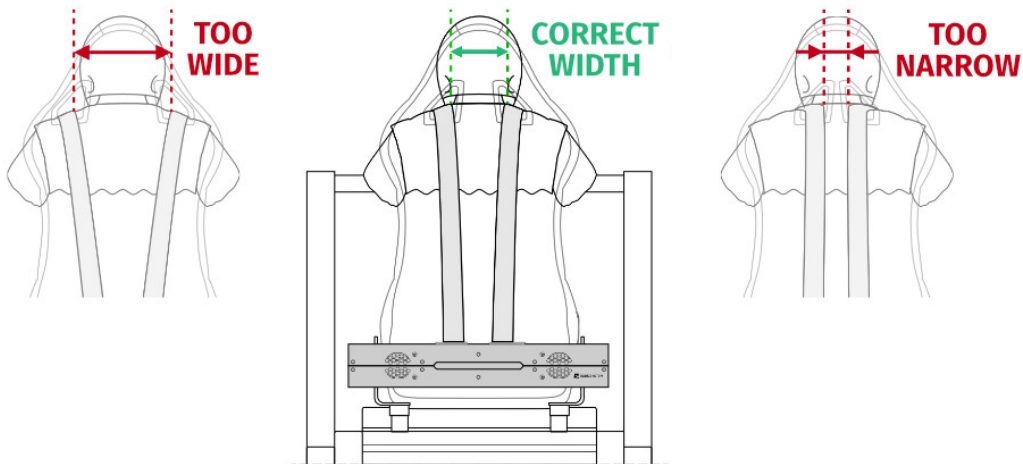

5.7.2 VEHICLE VS. FLIGHT SIMULATIONS SETUP

INFO

To have the most immersive experience in vehicle or flight simulations you need a compatible seat with specific seat belt slots height.

In **vehicle simulations** you should have **horizontal pulling force** instead of upward or downward pulling force. Seat belt slots should be at the same level as your shoulders.

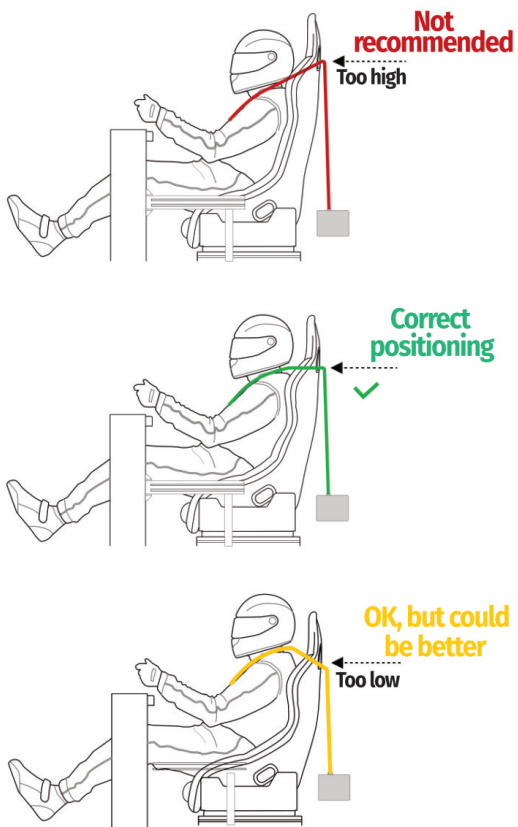

In **flight simulations** you should have **downward pulling force** instead of upward or horizontal pulling force. Seat belt slots should be positioned lower than your shoulders.

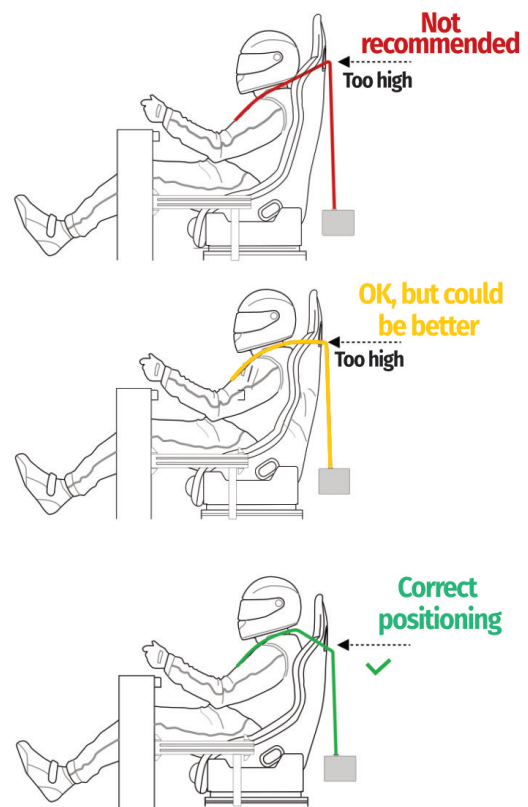

5.8. CABLE CONNECTIONS

5.8.1 BASIC CONNECTION DIAGRAMS

WARNING

The power supply **must be unplugged** when connecting rest of the cables.

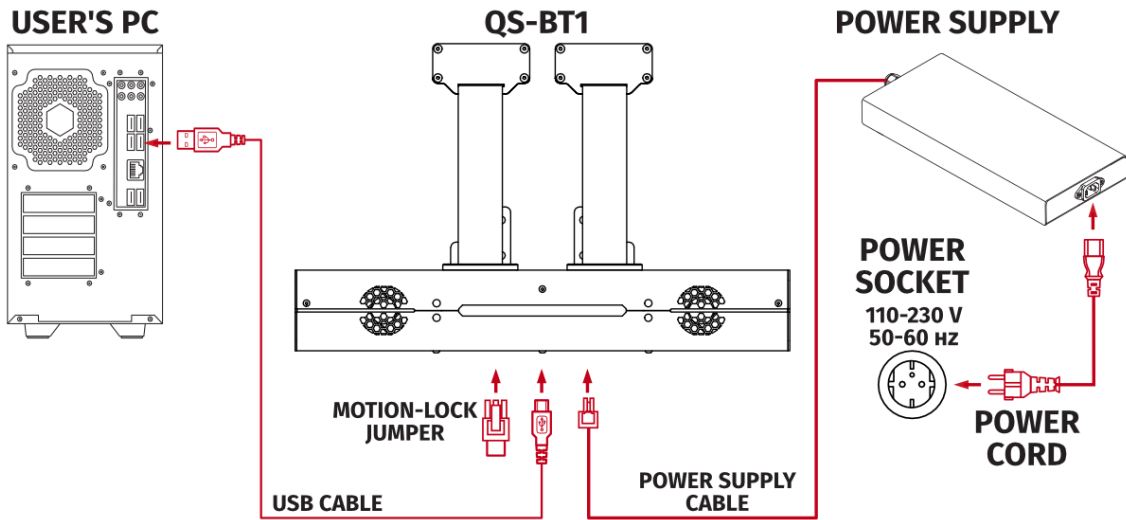

WARNING

If QS-BT1 works with no Motion Lock feature, then Motion Lock jumper **must** be plugged in, as shown in the illustration below.

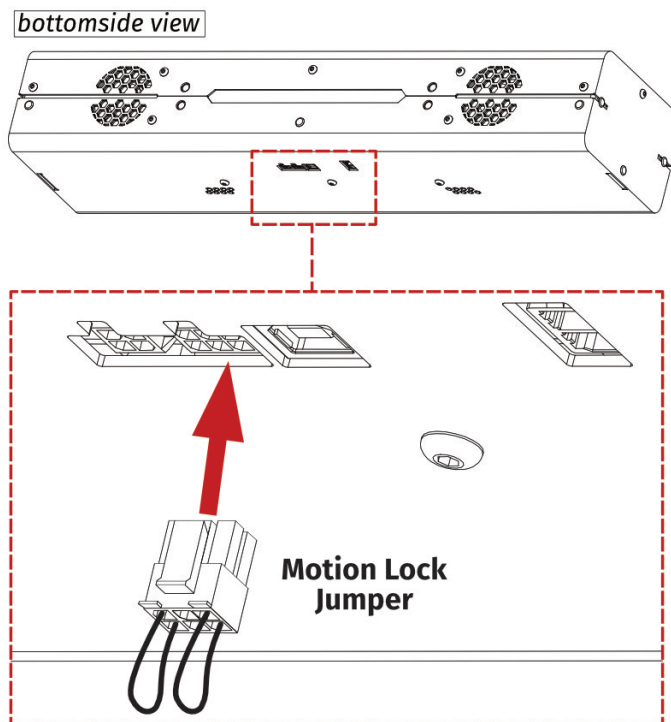

5.8.2 MOTION LOCK CONNECTION DIAGRAMS

It is **recommended** that you install a Motion Lock button within arm's reach of the user. It is possible to run QS-BT1 device individually with a dedicated Motion Lock button. It is not included and can be purchased separately as an accessory from our retailers.

WARNING

1. All Motion Lock connections must be performed with **power OFF**.
2. Motion Lock interlink cables have different ML/UP (6 pin) and ML/DN (4 pin) plugs on each side.
3. Motion Lock is not a standalone device - QS-BT1 must be plugged in to power and via USB to PC.

INFO

We recommend including QS-BT1 in the Motion Lock circuit, if you are running other QS-series devices. Refer to diagrams below.

1. Seat belt tensioner (QS-BT1) with two power cabinets (QS-210/220).

Variant #1

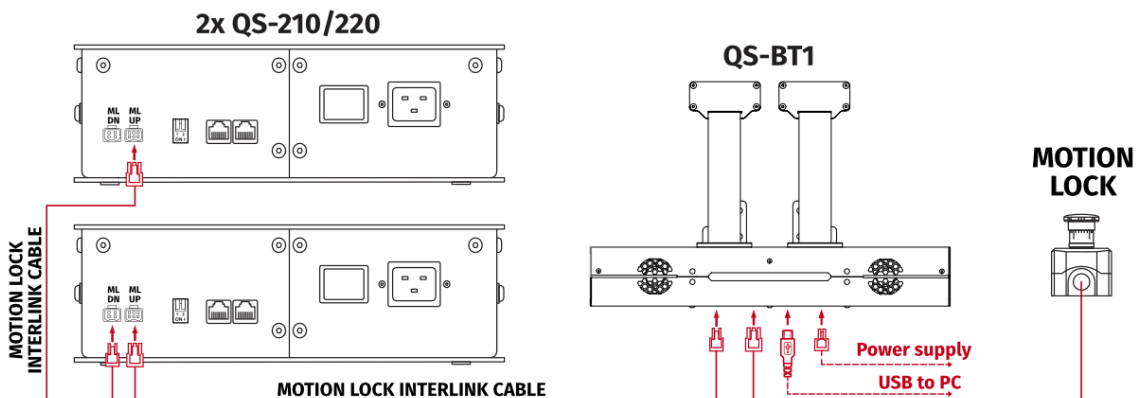

Variant #2

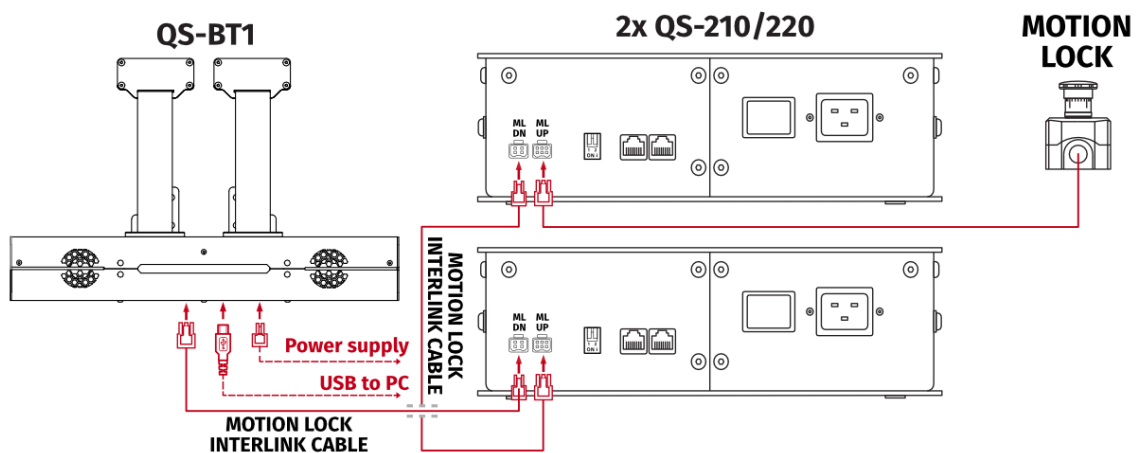

2. Seat belt tensioner (QS-BT1) with two power cabinets (QS-210/220) and a direct drive steering wheel (QS-DD-20).

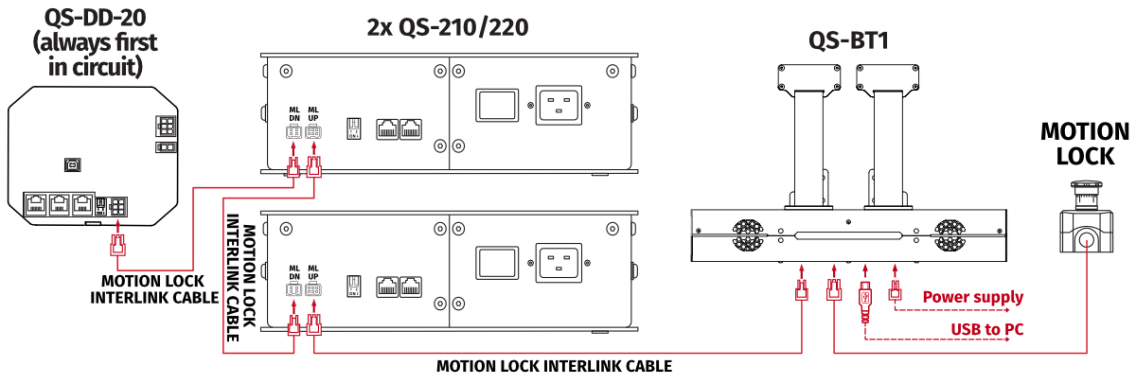

3. Seat belt tensioner (QS-BT1) with a direct drive steering wheel (QS-DD-20), motion platform (QS-CH2) and two power cabinets (QS-210/220).

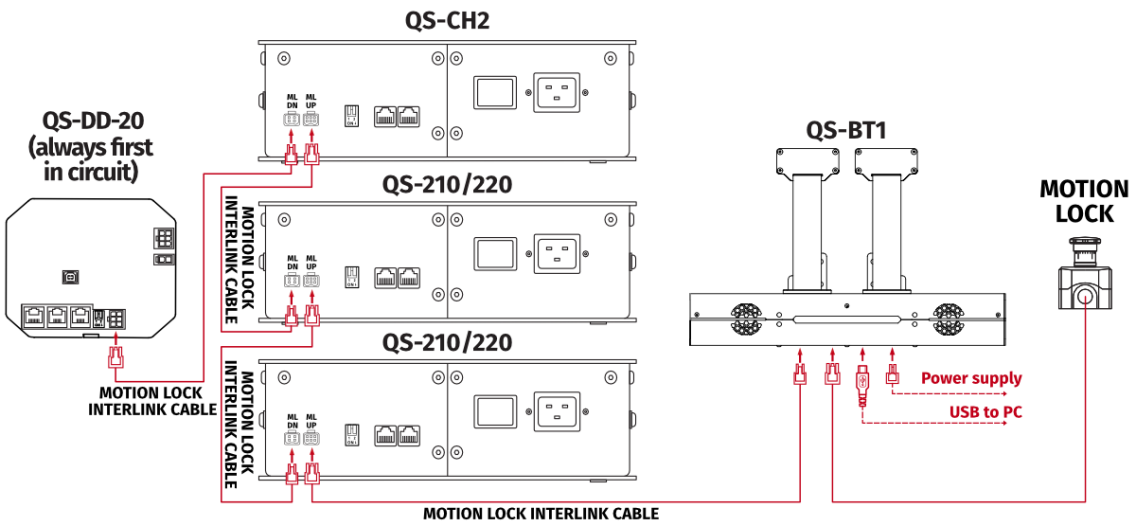

4. Seat belt tensioner (QS-BT1) with a direct drive steering wheel (QS-DD-20).

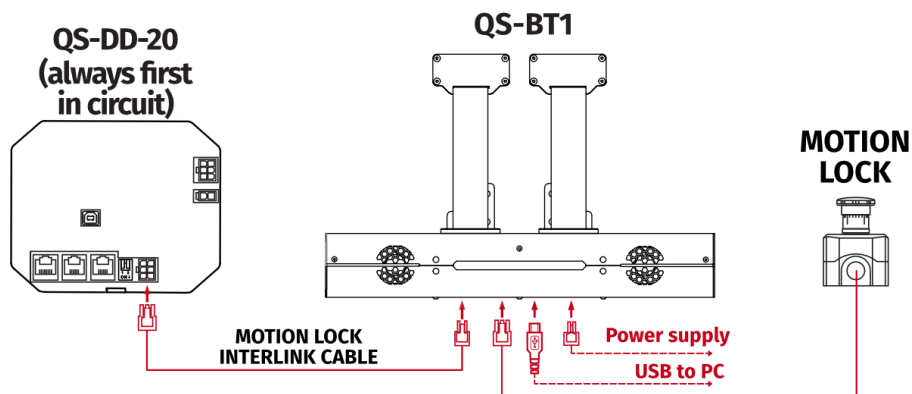

5. Seat belt tensioner (QS-BT1) with a motion platform (QS-CH2) and two power cabinets (QS-210/220).

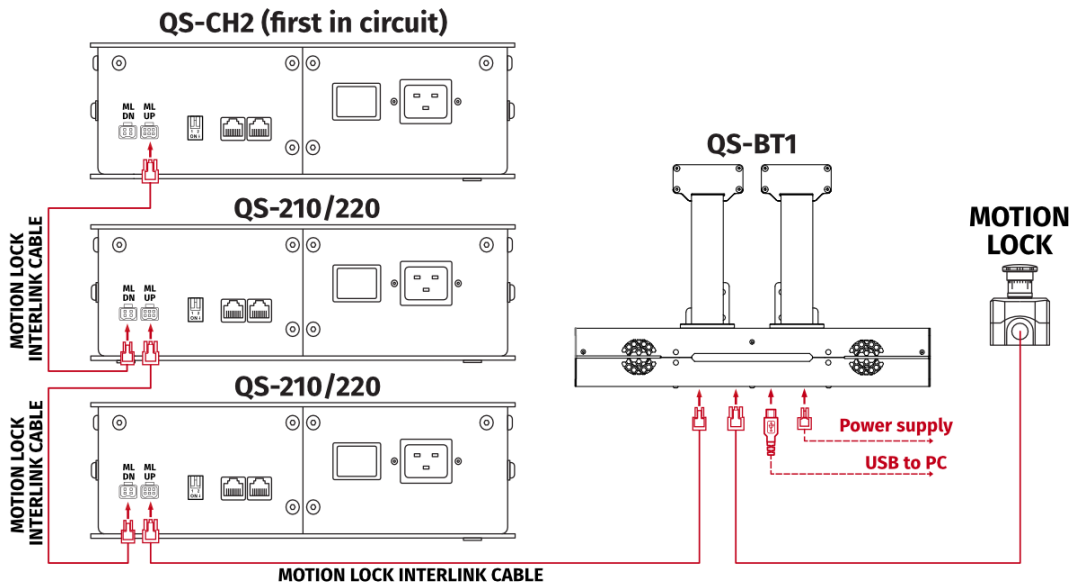

6. Seat belt tensioner (QS-BT1) with one power cabinet (QS-210/220).

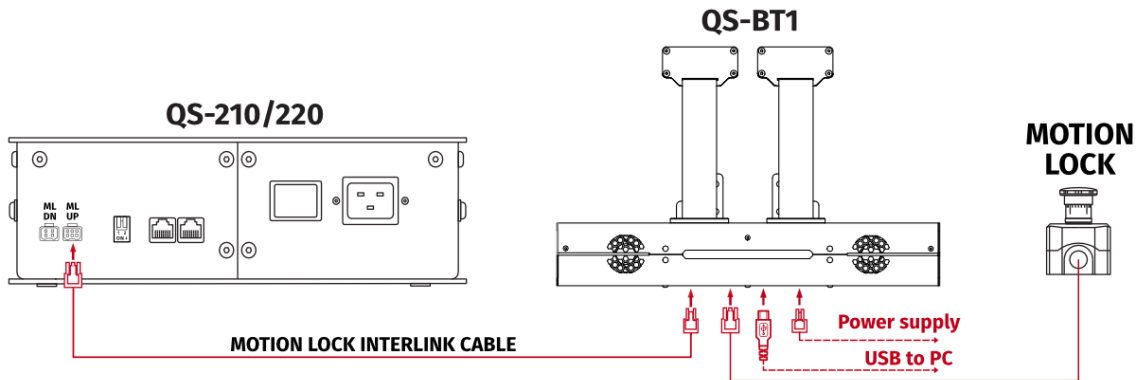

7. Seat belt tensioner (QS-BT1) with Motion Lock only.

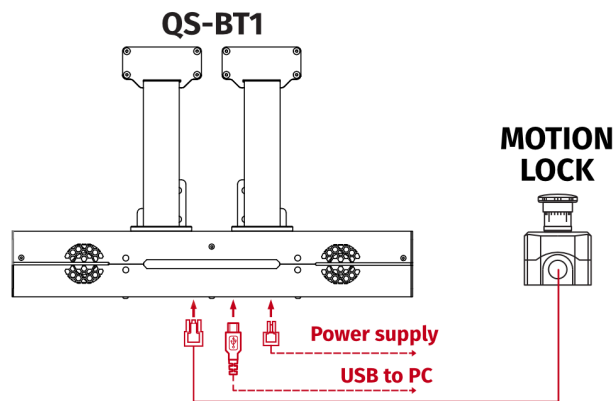

5.8.3 IMPLEMENTING NON-FACTORY MOTION LOCK SWITCH

For non-factory Motion Lock plug setup, you must assemble plug and connectors as shown below:

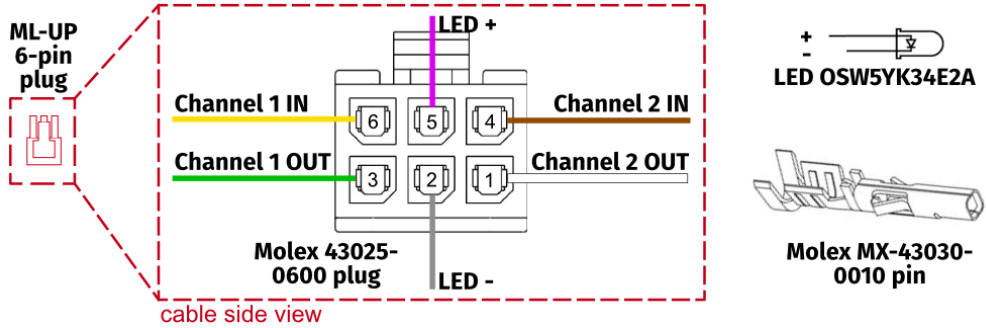

If you want to assemble custom Motion Lock switch or a button box setup (only Double Pole Single Throw switch compatible) using QubicSystem Motion Lock interlink cable, follow the diagrams below:

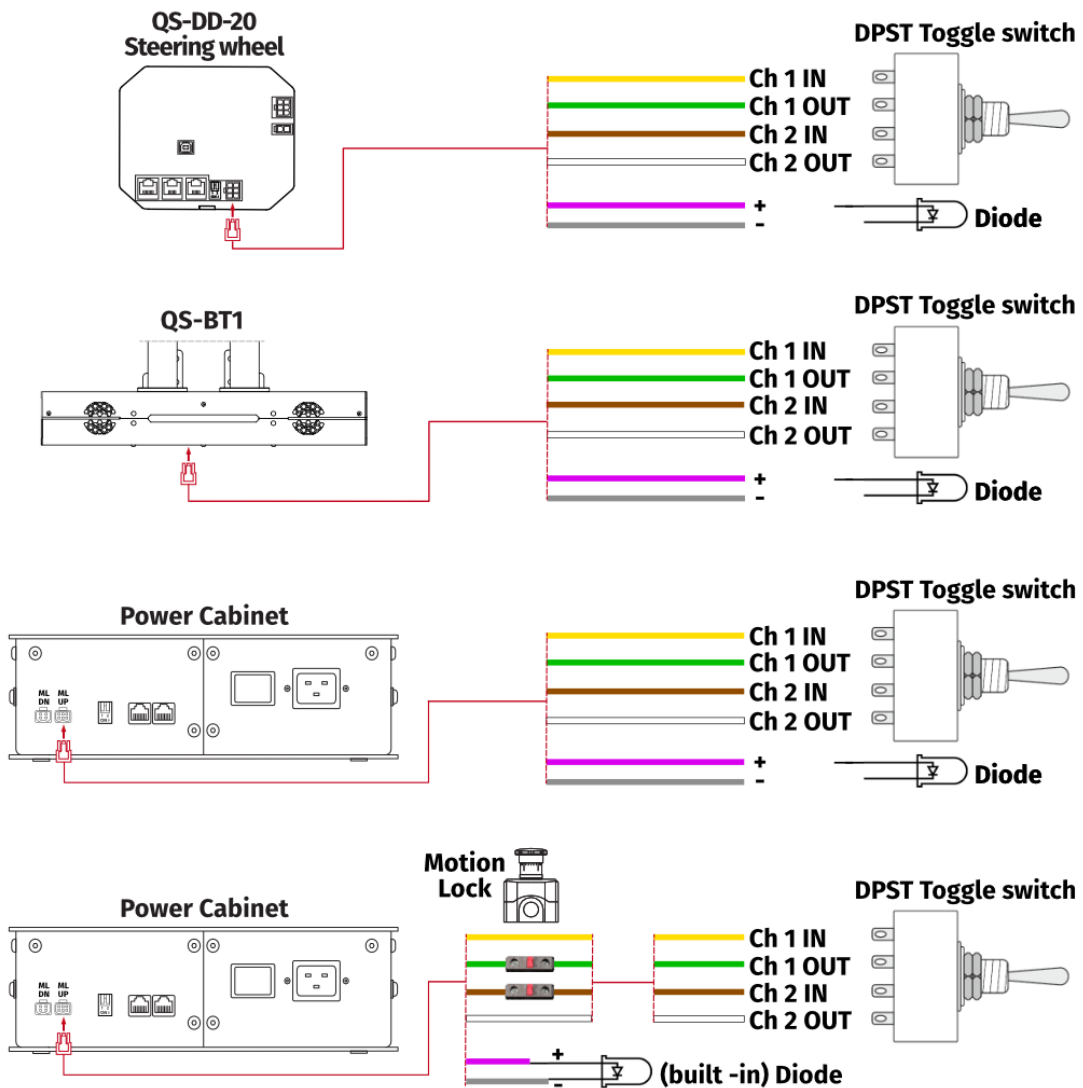

5.9. POST-ASSEMBLY CHECK LIST

After successfully connecting the QS-BT1 to the power, PC and installation to the platform - check if everything is ready to operate:

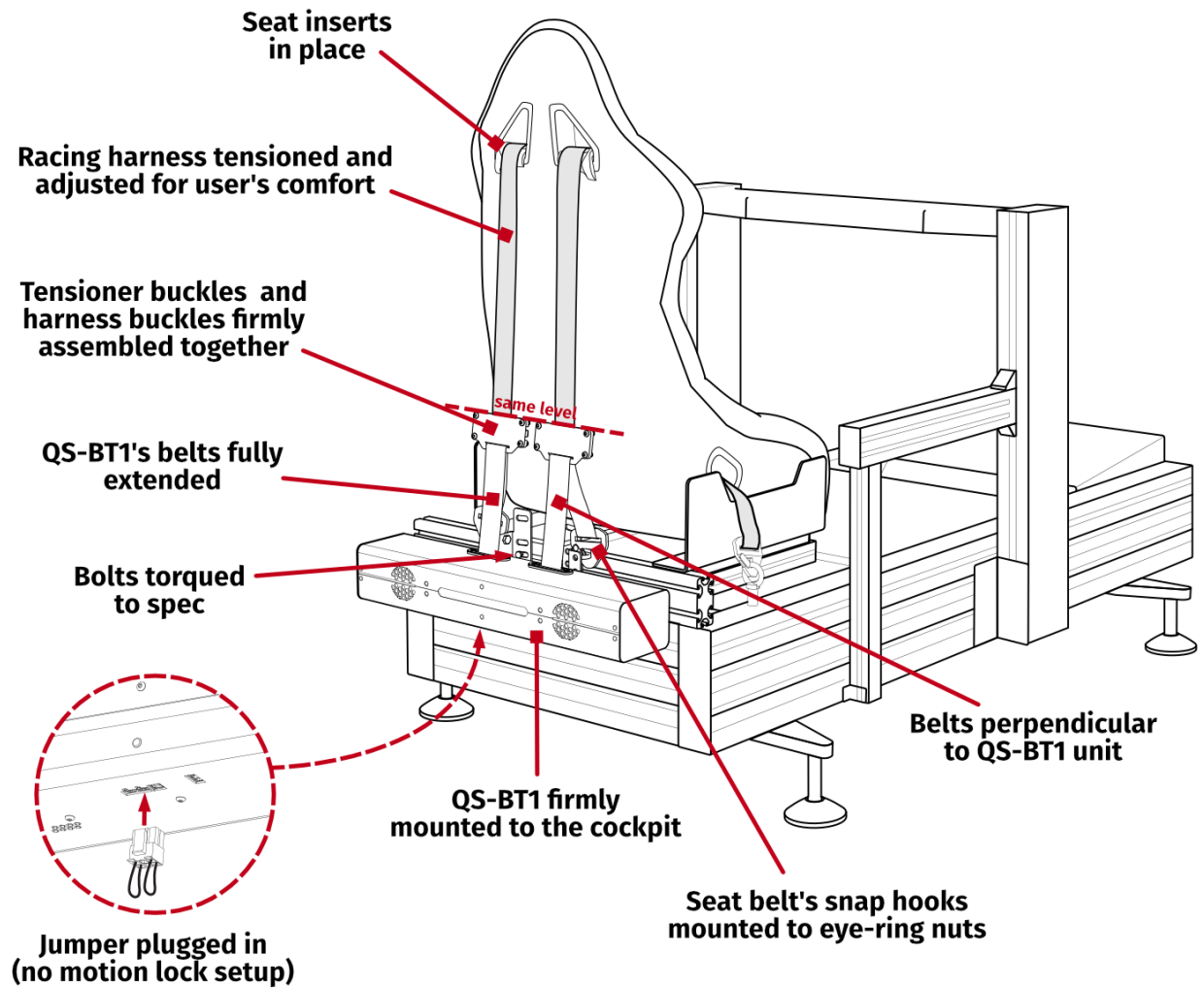

6. SOFTWARE

INFO

- This section refers to the QubicManager, which is the default Qubic Systems software. If you already own another Qubic System device, the QS-BT1 will be automatically added to your device list in the QubicManager after connecting and powering up.
- QubicManager is the same software that is used to manage other motion platforms.

6.1. QS-BT1 SOFTWARE COMPATIBILITY

Choose the software based on your primary motion platform family.

Motion Platform Model	Qubic Manager	ForceSeatPM	Next Level Racing® Platform Manager
QS-BT1	✓	✓*	X
QS-210	✓	✓*	X
QS-220	✓	✓*	X
QS-CH2	✓	✓*	X
QS-S25	✓	✓*	X
QS-V20	✓	✓*	X
PS-6TM-XXX	X	✓	X
PS-6TL-XXX	X	✓	X
PS-3TM-XXX	X	✓	X
PS-2RM-XXX	X	✓	X
Next Level Racing® Motion V3	✓	X	✓
Next Level Racing® Motion Plus	✓	X	✓
Next Level Racing® Traction Plus	✓	X	✓
No motion platform	✓	✓*	X
3rd party motion platform	✓	✓*	X

*ForceSeatPM will also work but it is recommended to use QubicManager

WARNING

If you have previously installed the software, ensure that it is up to date before running the QS-BT1.

6.2. DOWNLOAD AND INSTALLATION

INFO

If you already have software installed, no changes are necessary - device will be automatically added to device list, and all steps from this section should be skipped.

The **SERIAL NUMBER** required to access software download can be found on the underside of the belt tensioner housing. It's printed on the rating label in the **XXXXXX-XXXXXX-XXXXXX** format.

Serial Number is also available on the side of packaging box.

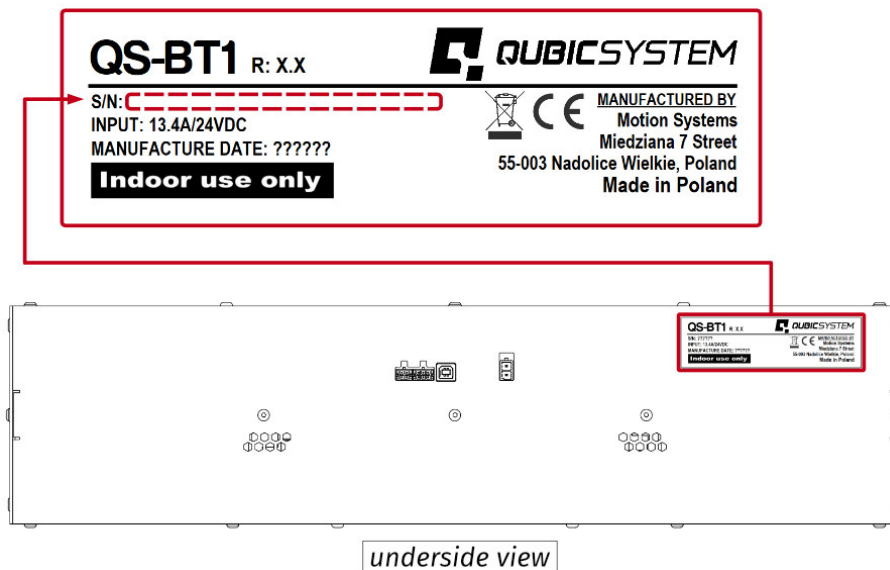

Software installation procedure:

1. Connect the devices according to the interconnection diagram without connecting the power supply unit to the power socket - see section 5.8 on page 40 (if it is equipped with a power switch, keep it in OFF position).
2. Download QubicManager from QubicSystem.com/Download
3. Enter the serial number located on the identification label.
4. Proceed with the installation steps and launch the application.
5. Turn on the device by connecting power supply unit to the power socket (if it is equipped with a power switch, turn it ON).
6. If QubicManager has recognized the QS-BT1 correctly, the status of the device will change to **Connected**. Device status is visible in the lower left corner.

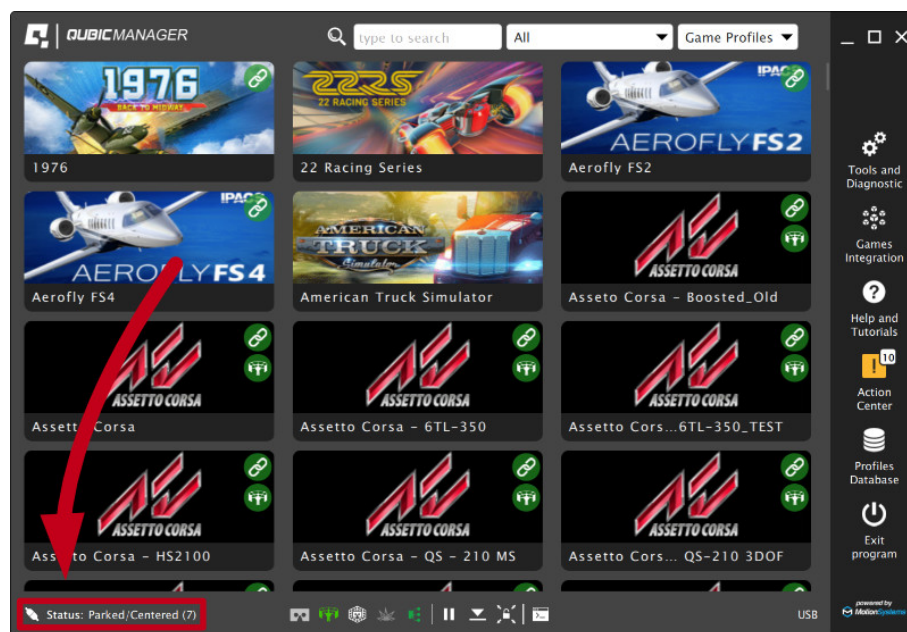

7. Check the **Action Center** on the right side panel for a list of actions that require attention. It is possible to solve them one by one or by pressing the **Resolve All** button. Firmware updates may require additional confirmation in the dialogue box.

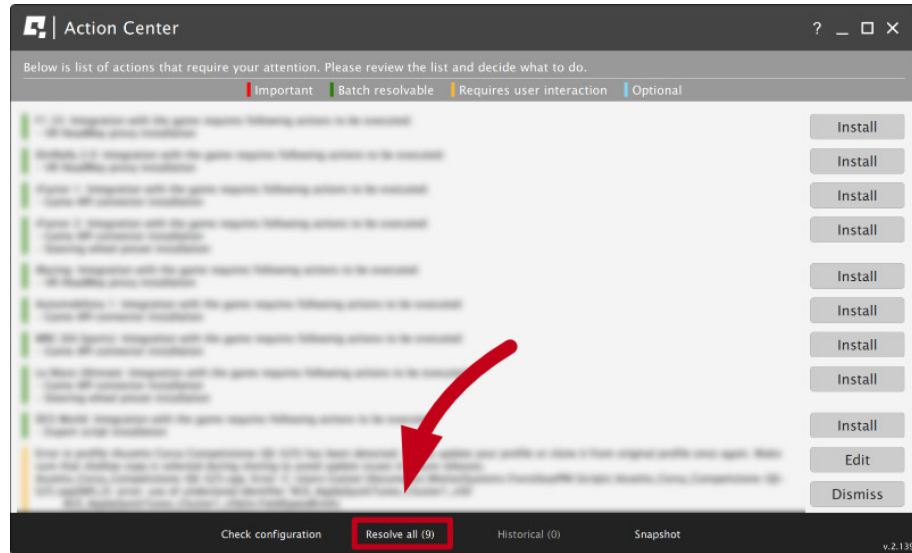

6.3. ADJUSTMENTS

1. Select the profile in the Qubic Manager main application window:

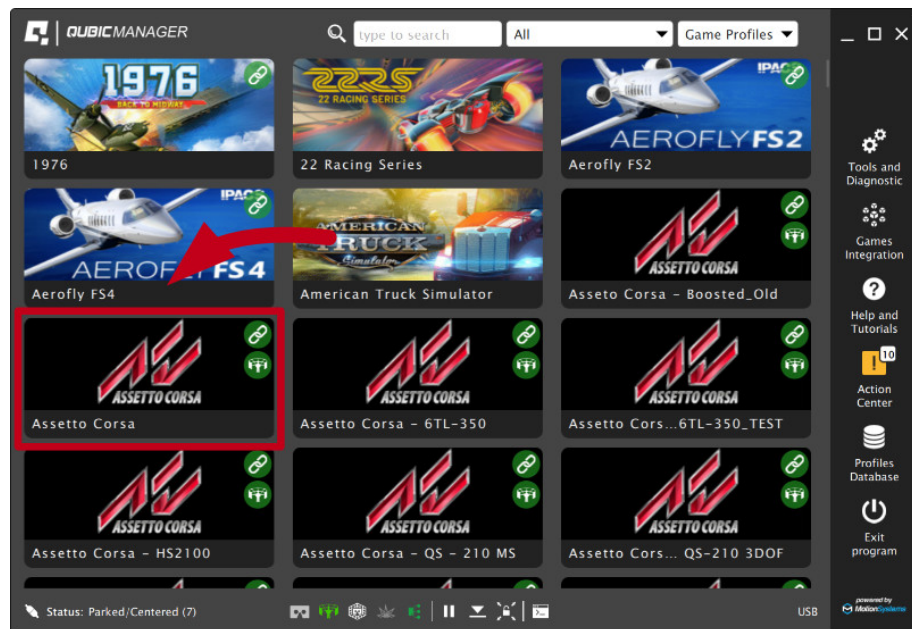

- In the profile window, in the tab "Seat Belt Tensioner" select "Main" or "SFX" and then adjust the settings to your own preferences using sliders in the profile window. Changes can be made "on the fly" without quitting or restarting the simulation application.

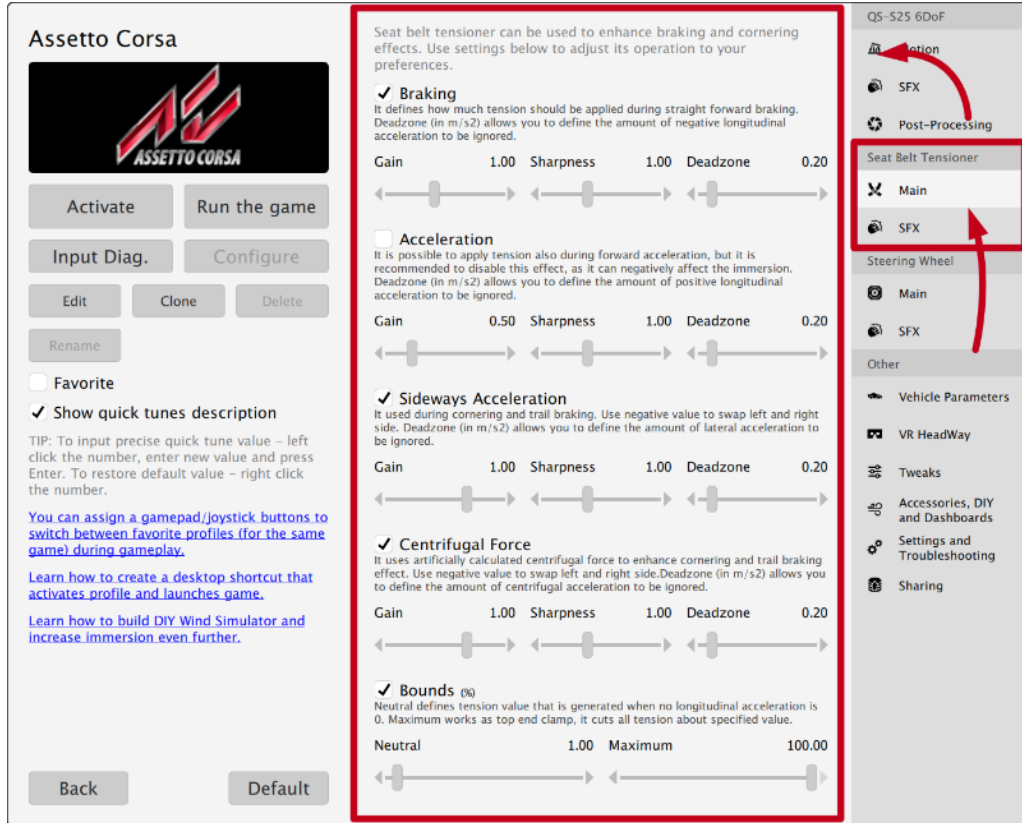

7. OPERATION

INFO

For connecting and setting up the QS-BT1, see section 5.8 at page 40.

1. After turning on the **QS-BT1**, red light scanning effect at the led bar begins. The device is in standby mode.



2. Launch QubicManager software (QS devices need QubicManager software to operate in background). For details refer to section 6 at page 46.
3. Activate a correct profile in QubicManager main application window. (if game is launched without activating a profile - software will activate a default profile automatically).
4. You may check the status of the device in bottom left corner - it should say "Connected".
5. **No calibration of the device is needed.**
6. The QS-BT1 will start tensioning the belts after in-game race or flying session will begin:
 - (a) In a racing simulation the **QS-BT1** will tension the belts (depending on a game) after firing the engine, first braking or a downshift action.
 - (b) In a flight simulation the **QS-BT1** will tension the belt (depending on a game) after sudden braking on a landing strip or a sudden control stick movement while in the air.
7. Anytime you pause or exit the game the **QS-BT1** will release the tension of the belts.
8. After you resume the game the **QS-BT1** will tension the belts again after any action from point 4 (a) or 4 (b) will occur.

8. TROUBLESHOOTING

WARNING

DO NOT attempt to do any repairs by yourself. It is dangerous and will result in loss of warranty! All repairs should be consulted with technical support and performed by a qualified technician.

Before contacting technical support, try this:

- Check the Action Center in QubicManager.
- Open the diagnostic window to check if the device is responsive.
 1. Select **Tools and Diagnostic** → **Seat Belt Tensioner Diagnostic**

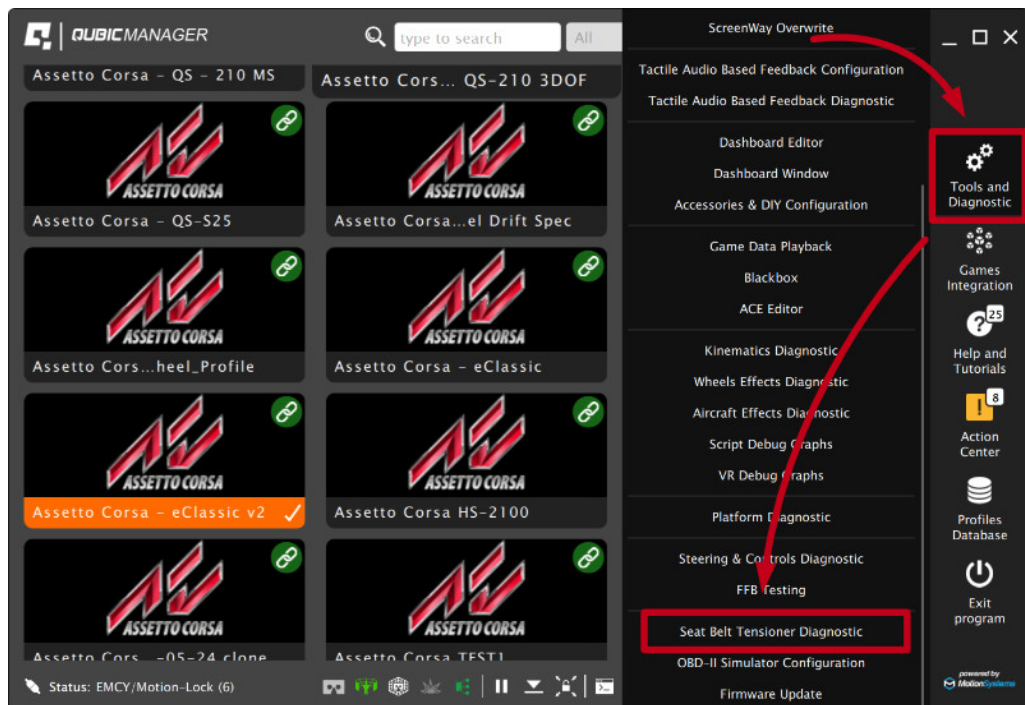

2. Diagnostic window allows pulling belts by using the sliders. It also displays the input data signal from the application.

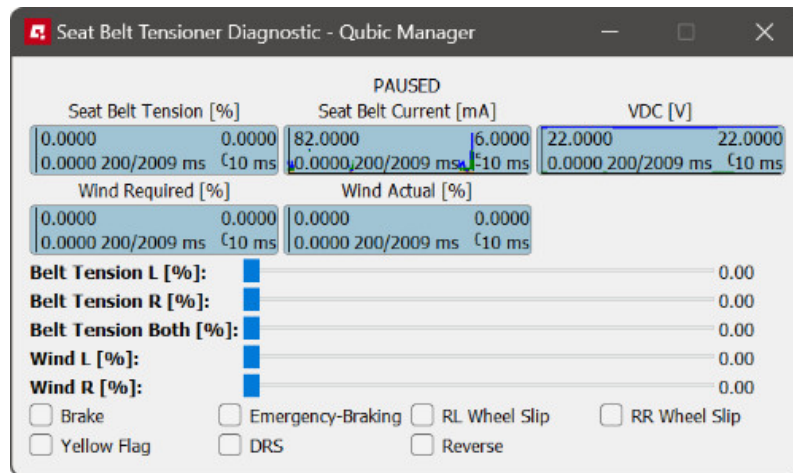

- Check all cable connections of the device. Refer to section 5.8 on page 40.
- Restart QubicManager application by right-clicking on the application icon in the system tray and selecting **Restart**

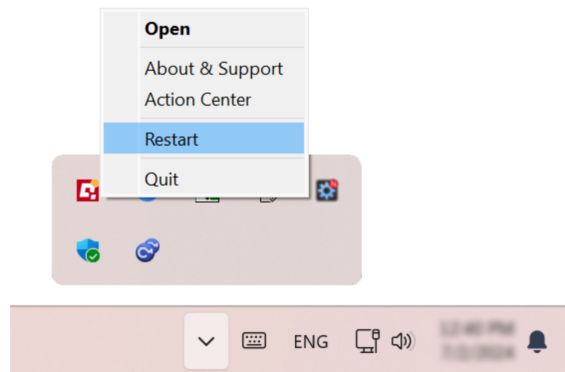

- Try different USB ports in your PC.
- If a problem occurs abruptly, it could be caused by thermal protection. Turn off QS-BT1, disconnect it from power outlets and wait at least 15 minutes to let it cool down.
- In case of any unclear electrical issues or strange behavior, contact technical support.
- If the device suffers from abnormal work conditions, please immediately contact the distributor/reseller for technical support.

INFO

If none of the diagnostic advice listed above works, create a snapshot. It compiles all the necessary details for technical support to resolve the issue.

8.1. COMMON PROBLEMS WITH SOLUTIONS

- **Problem:** Belts do not release/belt release is weak.

First **verify** if user's profile is causing the no-release problem - **constant flow of game inputs** may be making the belt tension without stop. To verify that:

1. Go to **QubicManager** → "**Tools and Diagnostics**" (1) → "**Seat Belt Tensioner Diagnostic**" (2).
2. Open and enlarge the "**Seat Belt Tension [%]**" (3) graph.
3. Right-click on it → "**Stay on top**" (4).

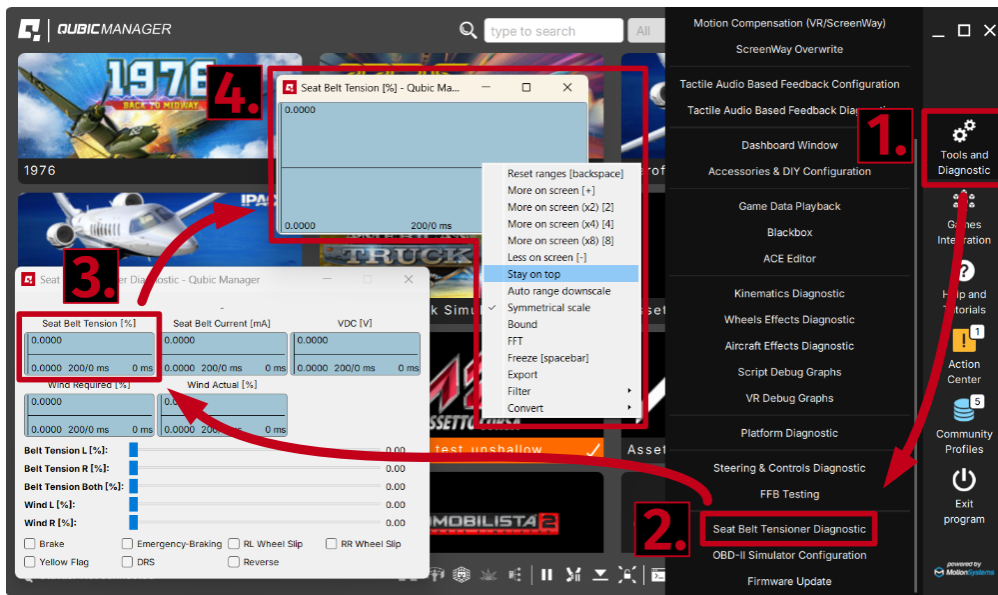

4. Check if lines ever go down to 0 during normal game session.

Solution #1: If the lines never go down - there is a **contant flow of inputs** from the game which cause the no-release problem. To limit them, it is suggested to start from disabling "Engine vibration" and "Bounds" effect.

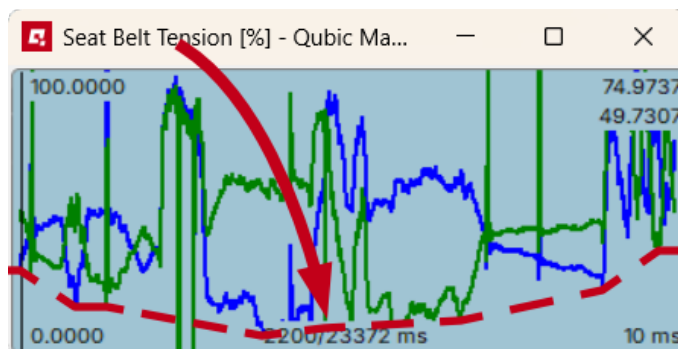

Solution #2: If the lines go down but belts do not release - **harness/belt's friction is too high**. Since the force of the belt tension is regulated by the motor, but the release of the belt is not, user must ensure the least possible friction on the harness and built-in belts. QS-BT1 must be mounted according to the manual

(section 1., p. 35). Low friction inserts must be installed (or possibly aftermarket roller setup - more info in section 5.6.3, p. 37).

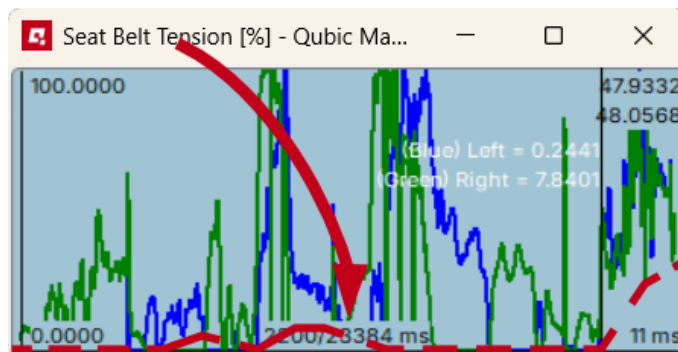

- **Problem:** Belts are not working symmetrically/one belt is weaker.

First **verify** that belts have symmetrical pulling force.

While the QS-BT1 is ON and the user is sitting in the rig with belts fastened:

1. Go to **QubicManager** → "**Tools and Diagnostics**" (1) → "**Seat Belt Tensioner Diagnostic**" (2).
2. Open and enlarge (double-click) the "**Seat Belt Current [mA]**" graph (3).
3. While observing the graph (4), move the slider "**Belt Tension Both [%]**" (5) **slowly** to the right and back to the left. Focus and feel whether the right and left belt pulls with the same force (small oscillations on graph are normal due to uneven mouse movement).

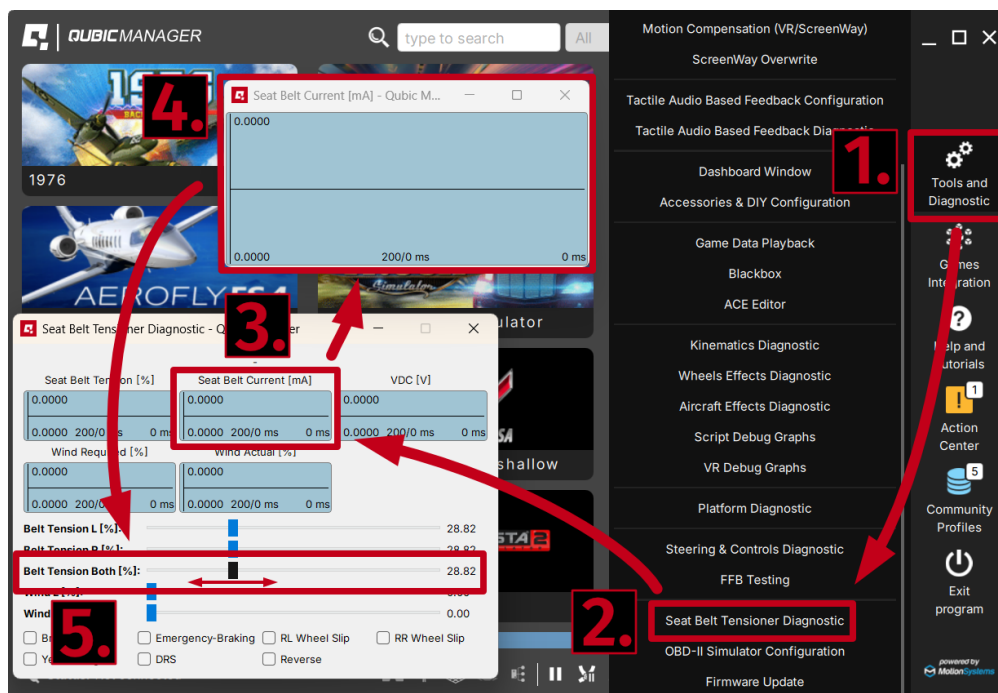

Solution #1: If the two lines (blue for left, green for right) match each other but user can feel belts working asymmetrically:

- there is too much friction on one of the sides
- the harness is installed incorrectly (unevenly, bolts not torqued down)
- the harness is coming loose on the chest adjusters
- QS-BT1 is not installed in vertical center axis of the seat which causes the belts to slip to the side and rub against the seat harness slot

Device or harness mounting must be checked and corrected according to the manual (section 1., p. 35 and section 5.9, p. 45) to ensure lowest friction possible.

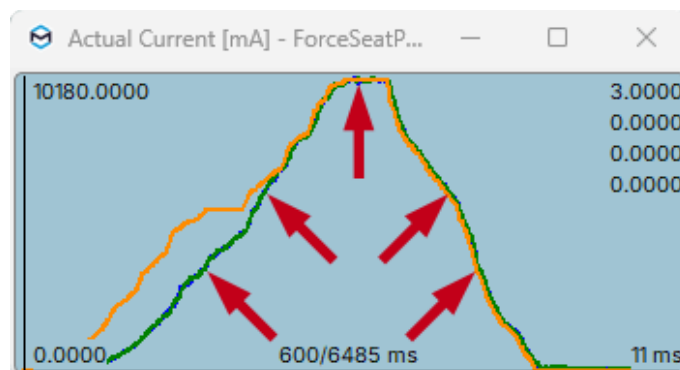

Solution #2: If two lines clearly do not match each other - report the problem to Technical support via application form on the [Motion Systems](#) website, including a snapshot file (section 8.2).

Solution #3: If there is no pulling force on one of the belts and the device is emitting unusual noises - report the problem to Technical support via application form on the [Motion Systems](#) website, including a video of a working QS-BT1.

-
- **Problem:** QS-BT1 does not calibrate at start-up.

Solution: QS-BT1 does not have a calibration procedure. Once the belts are fully extended and the device is connected according to the diagrams - it is ready to operate. Once in the game/simulation - the first input signal sent to the QS-BT1 will start tensioning the belts (for details on operation of the device, go to section 7, p. 51).

- **Problem:** QS-BT1 keeps disconnecting/does not connect at all.

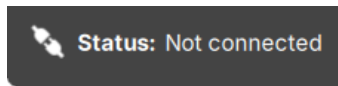

Solution #1: Make sure QubicManager software is up to date. Go to **QubicManager** → "Tools and Diagnostic" (1) → "About / Support" (2) → check the software version (3)

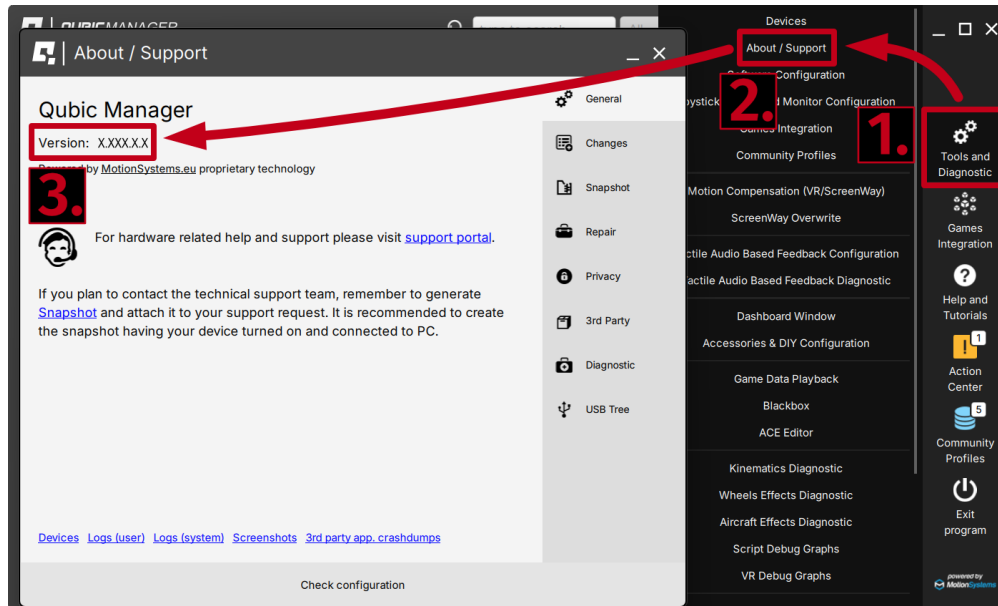

Compare it to newest software version listed on Qubic System website: **QubicSystem.com/qschangelog** → "Software" → "Changelog".

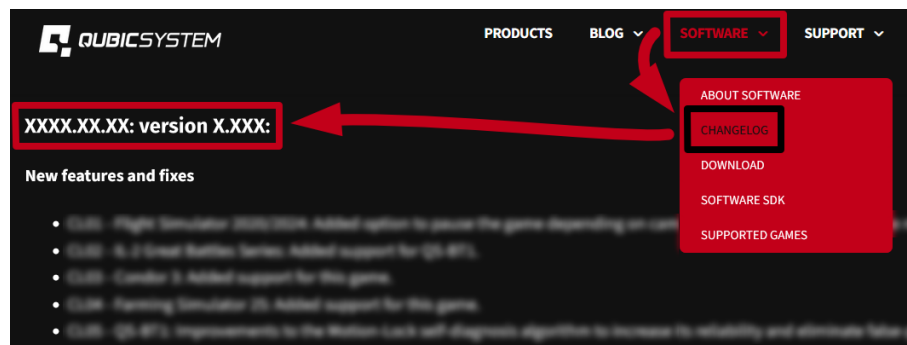

Solution #2: Check Action Center in QubicManager for pending issues. Click "Resolve all" button if there are any issues or resolve them one by one.

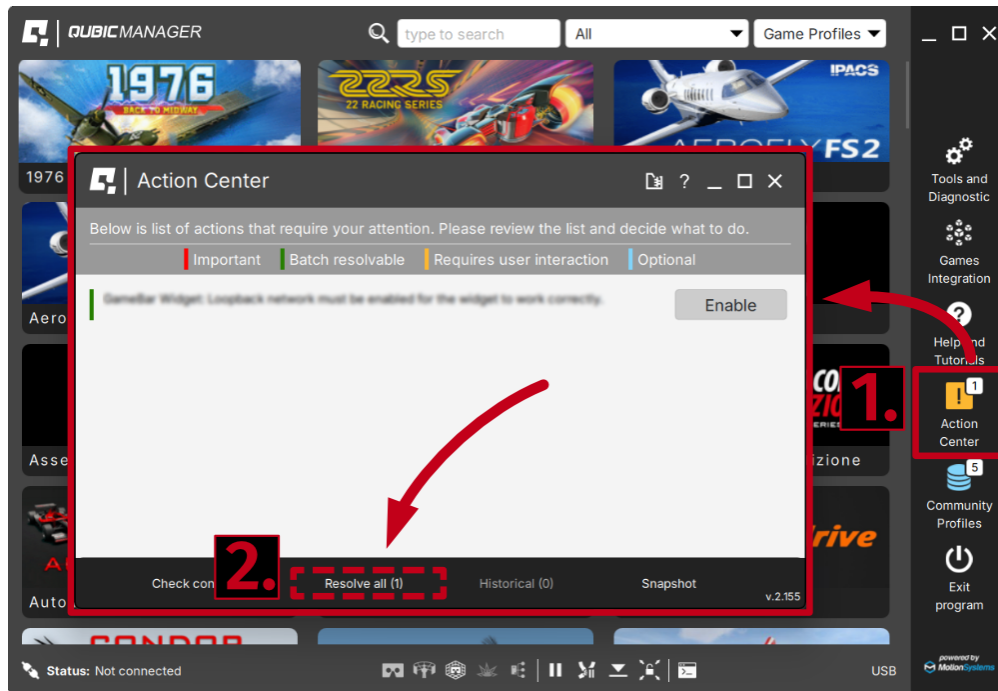

Solution #3: Pass over the USB Hub - connect the device directly to the PC.

Solution #4: Plug the QS-BT1 to a different USB Port.

Solution #5: Replace the original USB cord (Type B USB plug).



If none of the solutions above work - **report** the problem to Technical support via application form on the [Motion Systems](#) website and include a snapshot file (section 8.2).

■ **Problem:** QS-BT1 does not work when the car hits rumble strips/curbs.

Solution #1: To verify that QS-BT1 is working correctly try a different game/simulation. It is possible that different games/simulations will provide QS-BT1 with different data.

Solution #2: Activate a default game profile **(2)** (always the first one in a given game title list **(1)**) and bring all the sliders to a default setting by clicking "Default" button **(3)** and then "Yes to all".

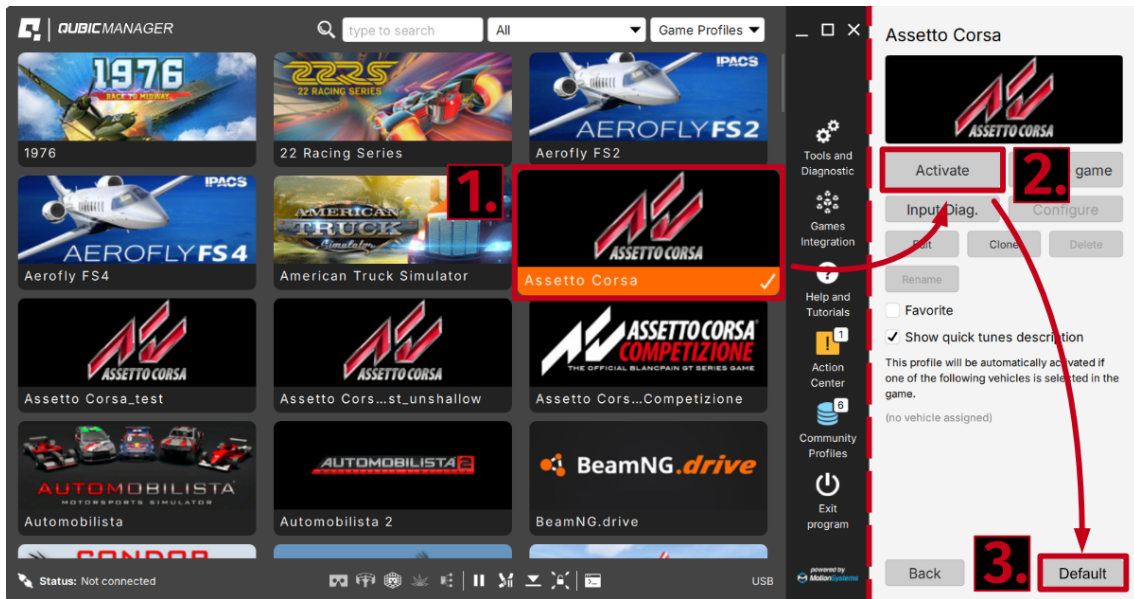

Solution #3: Increase Rumble strips/Road harshness slider value.

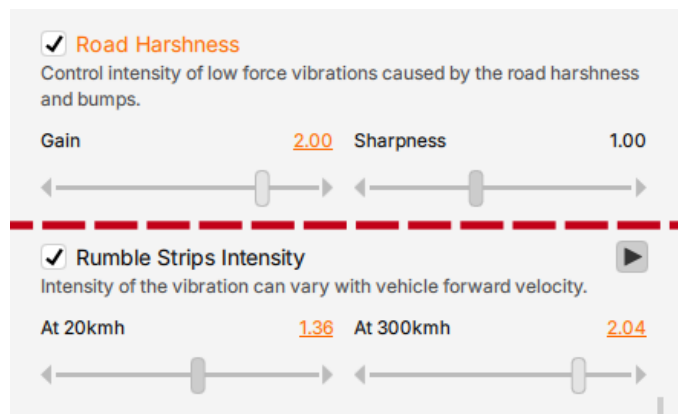

Tip: If QS-BT1 is working correctly and only the rumble strips/curbs are not present - most likely it is the lack of input from the game. To verify what input signal is being sent to any QS device - go to your currently activated game profile → **"Input diag."** and watch the graphs during typical game session.

Double click to open in a new window -> right click on a graph -> Stay on top.

Illustration of a "Kerb Vibration" graph after hitting a rumble strip:

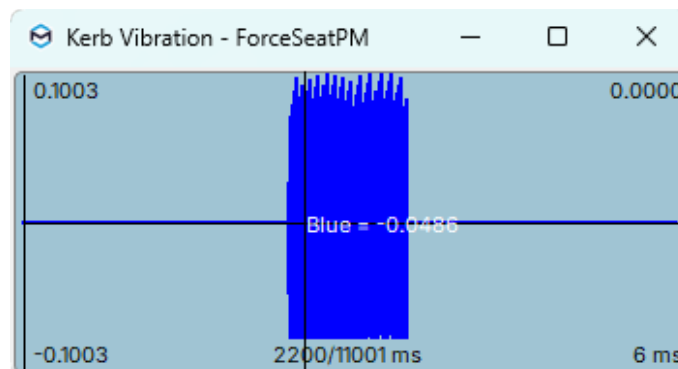

8.2. CREATING A SNAPSHOT

A snapshot is the easiest and fastest way to diagnose a problem. If you send in the zip file generated in the snapshot along with a description of the problem, technical support receives the necessary information about the product and its configuration. It can be then analyzed to provide the best solution.

WARNING

The QS-BT1 and all interconnected Power Cabinets **MUST BE** be powered up when creating the snapshot.

1. Open the main window of the Qubic Manager application.
2. Go to **Tools and Diagnostic** → **About / Support**

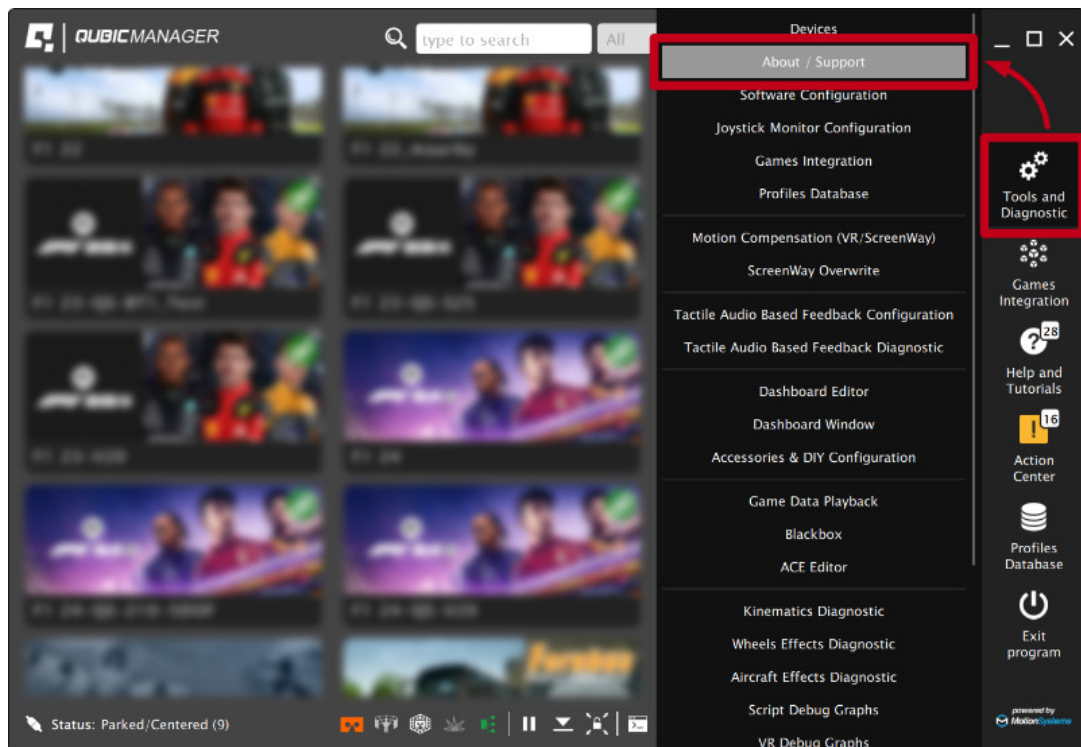

3. Open the **Snapshot** window:

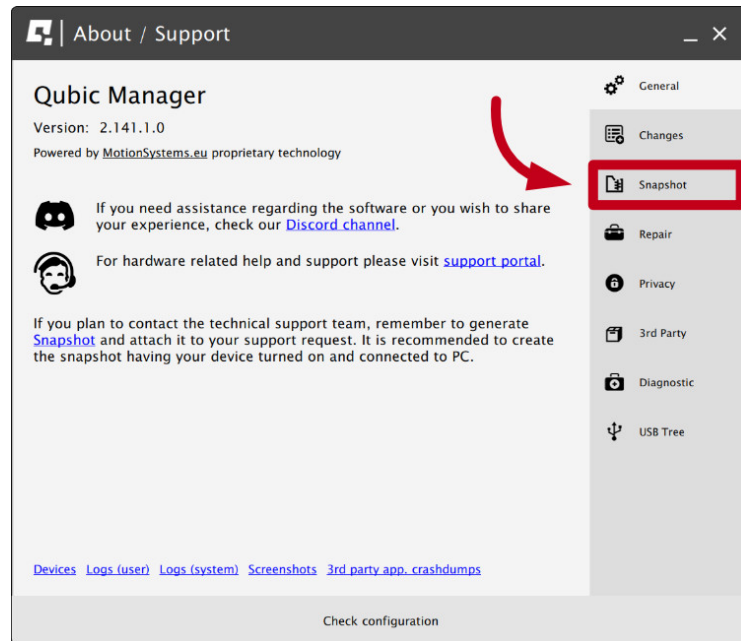

4. Select the data that will be included in the snapshot.

5. Scroll down, consent to the technical support terms and conditions and select **Create & Show**.

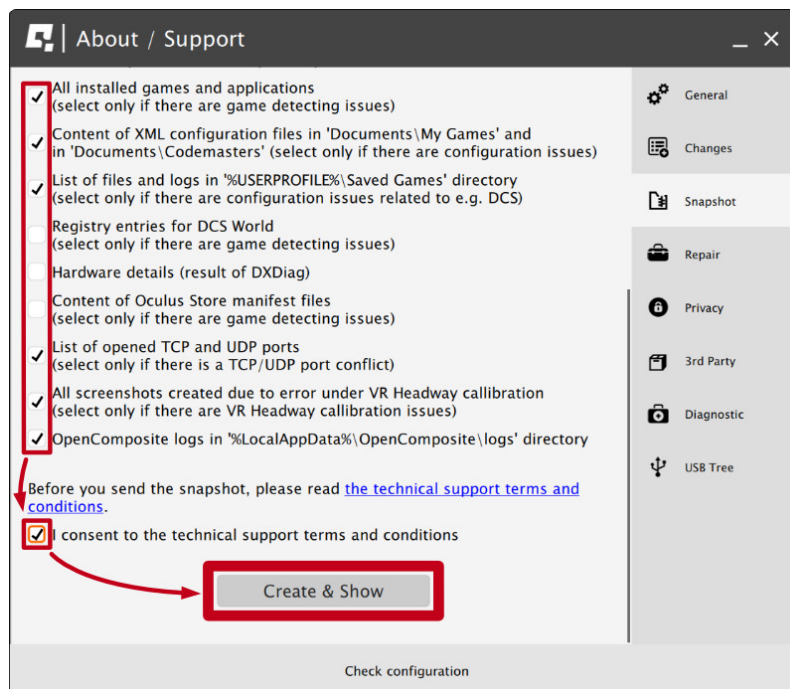

6. Wait for the processing to finish. After the snapshot has been created, click on the **OK** button - the folder with the snapshot ZIP file will open.

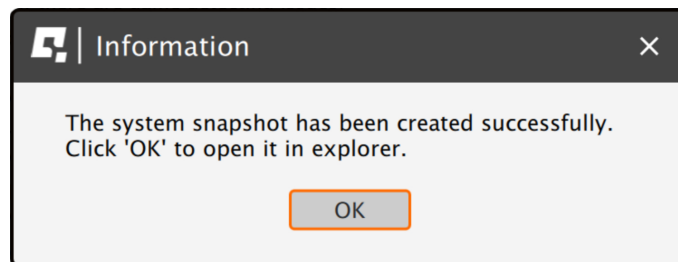

7. Attach the snapshot ZIP file to your support request.

8.3. DISCORD CHANNEL

We strongly recommend joining our discord channel, where our growing community is sharing amazing tips and ideas of how to set up, use and tune the Qubic System products. You can also send questions for technical support or get answers directly from the community.

Join our discord channel by following the invitation link:

<https://discord.com/invite/tuAtybvTRn>



9. ENVIRONMENTAL IMPACT AND DISPOSAL



DO NOT dispose of this product with standard household waste but drop it off at a collection point for the disposal of Waste Electrical and Electronic Equipment for recycling.

QS-BT1 is shipped with wooden cases/cardboard boxes. If the packaging is no longer needed, it can be fully recycled.

QS-BT1 is an advanced device and if stored or disposed of incorrectly it could harm the environment or/and other people. When the device is no longer in use it should be disposed in environmental safe manner in compliance with applicable local work and environmental protection regulations. If no other agreement of disposal was concluded, the device shall be dismantled for disposal as follows:

- Metal parts should be scrapped.
- Electric and electronic components should be disposed of in the specialized disposal center.
- Other materials should be sorted and disposed of accordingly to the local law and regulations.

10. LIABILITY DISCLAIMER

If permitted under applicable law, Motion Systems and its subsidiaries disclaim all liability for any damages caused by one or more of the following:

- The product has been modified, opened, or altered.
- Failure to comply with assembly instructions.
- Inappropriate or abusive use, negligence, an accident (an impact - for example).
- Normal wear.

INFO

If permitted under applicable law, Motion Systems and its subsidiaries disclaim all liability for any damages unrelated to the material or manufacturing defect with respect to the product (including, but not limited to, any damages caused directly or indirectly by any software, or by combining the QS-BT1 with any unsuitable element or other elements not supplied or not approved by Motion Systems for this product).

11. WARRANTY

Motion Systems warrants to the consumer that this product shall be free from defects in materials and workmanship, for a warranty period which corresponds to the time limit to bring an action for concerning this product.

For commercial customers, there is a one (1) year limited warranty, starting on the original date of purchase.

Within the warranty period, the product will be repaired or replaced free of charge, excluding shipping charges.

This warranty shall not apply:

- If the product has been modified, opened, altered, or has suffered damage as a result of inappropriate or abusive use, negligence, an accident, normal wear, or any other cause unrelated to a material or manufacturing defect (including, but not limited to, combining the QS-BT1 with any unsuitable element, including in particular power supplies, chargers, or any other elements not supplied or approved by Motion Systems for this product).
- In the event of failure to comply with the instructions provided by technical support.
- To software (said software being subject to a specific warranty).
- To accessories (cables, cases, for example).
- If the product was sold at public auction or if the product has suffered damage as a result of force majeure: flood, fire, earthquake, storm.

This warranty is non-transferable. No new warranty period commences if the product is repaired or replaced. Your statutory rights towards the seller are not affected or restricted by this warranty. Motion Systems, and their partners are not liable for any indirect, incidental, or punitive damages from use of this product. In case of malfunction during the warranty period immediately contact technical support.

12. COPYRIGHT

Qubic System is a trademark of Motion Systems. All rights reserved.

All the contents in this user manual are the intellectual property of Motion Systems. No part of this manual, including the products and software described in it, shall be modified or translated into any language without the prior written permission of Motion Systems. Specifications and information in this manual are subject to change at any time without obligation to notify any person of such revision or changes. Illustrations are not binding.

INFO

Trademark Notice - All brand names, icons, and trademarks that appeared in this manual are the sole property of their respective holders.

13. MANUFACTURER INFORMATION

Qubic System is a brand
that belongs to **Motion Systems**

HQ address:
Miedziana 7 Street
55-003 Nadolice Wielkie
Poland



Motion Systems homepage



QubicSystem homepage

INFO

In support queries please contact your reseller.

 QUBICSYSTEM



Q5 BT1